

Features

- Full Power at Wide Output Current Range (Constant Power)
- Adjustable Output Current (AOC) with NFC
- DALI-2 Certified (Part 251, 252, 253)
- 3-Timer-Modes Dimmable
- Dim-to-Off with Standby Power $\leq 0.5W$
- Integrated Power Monitoring with High Accuracy up to $\pm 1\%$
- Output Lumen Compensation
- End-of-Life Indicator
- Input Surge Protection: DM 6kV, CM 10kV
- All-Around Protection: IUVP, IOVP, OVP, SCP, OTP
- IP66/IP67
UL Dry/Damp/Wet Location (ET/EG models)
- TYPE HL, for Use in a Class I, Division 2 Hazardous (Classified) Location (ET/EG models)
- Suitable for Luminaires with Protection Class I
- Suitable for Luminaires with Protection Class I and II (EE models)
- 5 Years Warranty

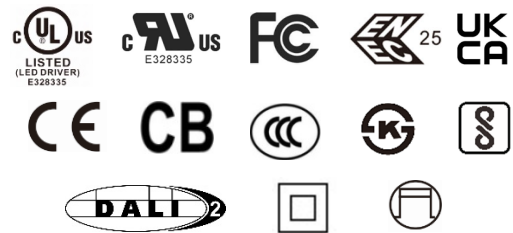

Description

The EUM-150SxxxEx series is a 150W, DALI-2, constant-current, NFC programmable and IP66/IP67 rated LED driver that operates from 90-305Vac input with excellent power factor. Created for intra-luminaire solutions and health monitoring applications, this family provides integrated AC power monitoring and dim-to-off functionality. The dimming control supports two-way communication via DALI-2. The high efficiency of these drivers and compact metal case enables them to run cooler, significantly improving reliability and extending product life. To ensure trouble-free operation, protection is provided against input surge, input under voltage, input over voltage, output over voltage, short circuit, and over temperature.

Models

Adjustable Output Current Range (mA)	Full-Power Current Range (mA) ⁽¹⁾	Default Output Current (mA)	Output Voltage Range (Vdc)	Max. Output Power (W)	Typical Efficiency ⁽²⁾	Typical Power Factor		Model Number ⁽³⁾⁽⁵⁾⁽⁶⁾
						120Vac	220Vac	
53-700	530-700	530	107-284	150	94.0%	0.99	0.96	EUM-150S070Ex
70-1050	700-1050	700	72-214	150	93.5%	0.99	0.96	EUM-150S105Ex
105-1500	1050-1500	1050	50-143	150	93.5%	0.99	0.96	EUM-150S150Ex
140-2100	1400-2100	1400	36-107	150	93.0%	0.99	0.96	EUM-150S210Ex ⁽⁴⁾
268-4200	2680-4200	3150	18-56	150	92.0%	0.99	0.96	EUM-150S420Ex ⁽⁴⁾

- Notes:** (1) Output current range with constant power at 150W
 (2) Measured at 100% load and 220Vac input (see below "General Specifications" for details).
 (3) Certified input voltage range: UL, FCC 100-277Vac; otherwise 100-240Vac.
 (4) SELV Output.
 (5) All the models are certificated to KS, except EUM-150S070Ex
 (6) x = G are UL Recognized, ENEC and CCC, etc. models; x = T are UL Class P models; x = E are Class II models with ENEC, etc. x = B are BIS models. See below "Mechanical Outline" for details.

I-V Operation Area

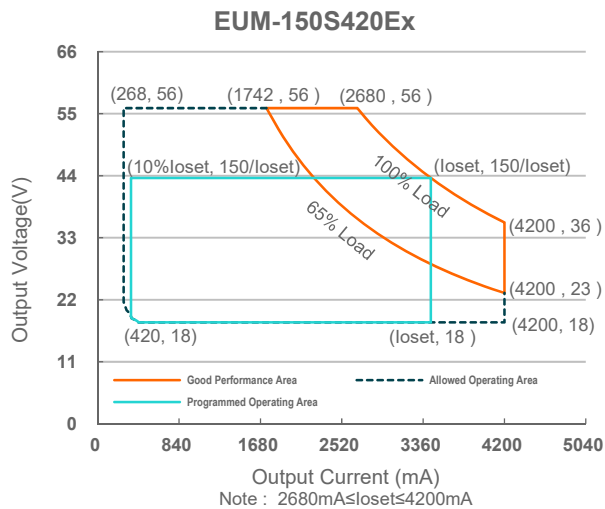
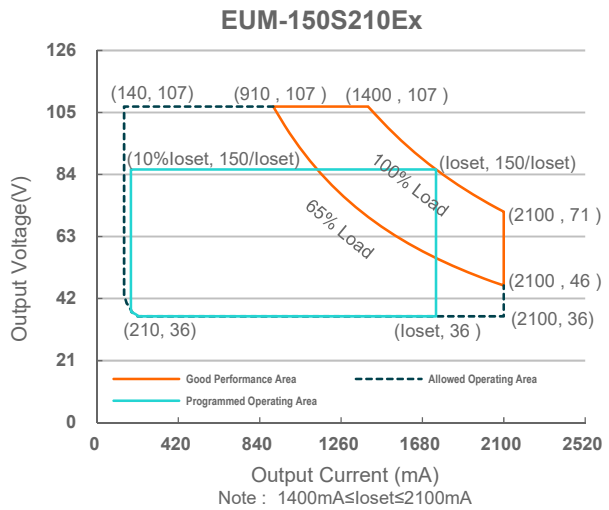
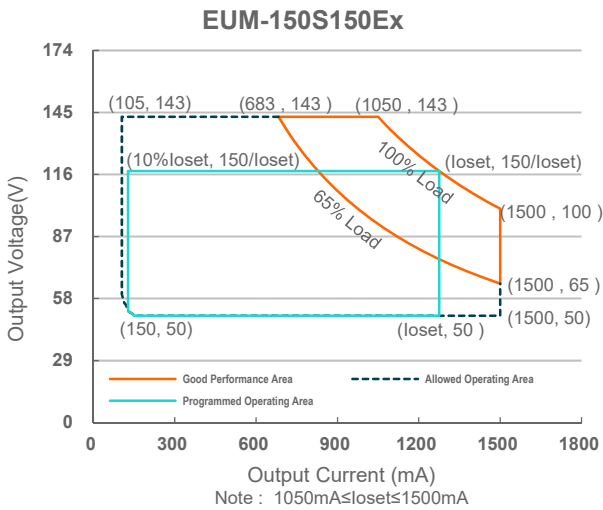
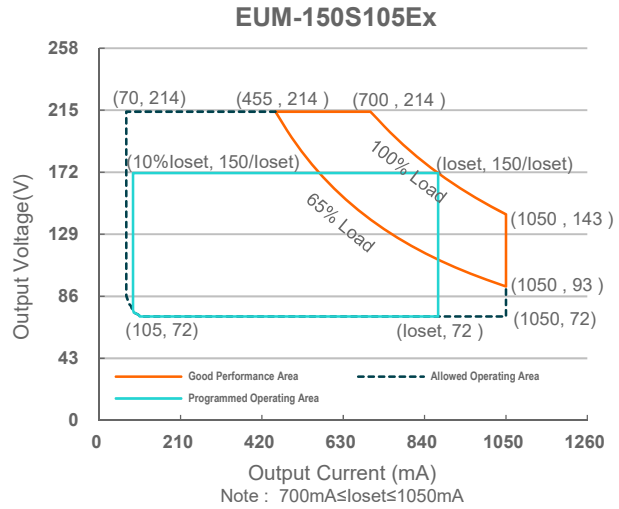
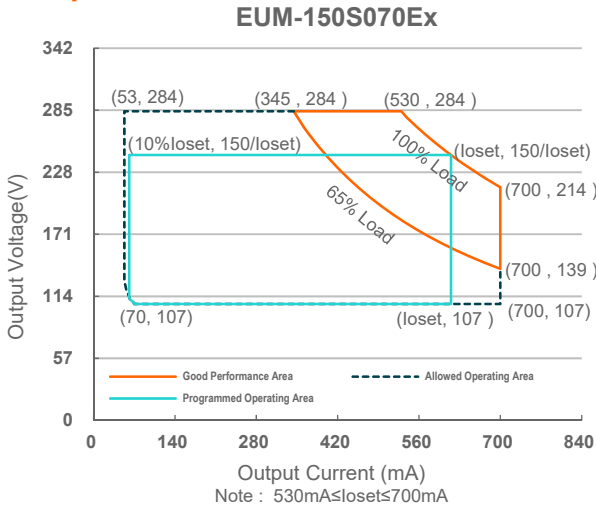

Input Specifications

Parameter	Min.	Typ.	Max.	Notes
Input AC Voltage	90 Vac	-	305 Vac	
Input DC Voltage	127 Vdc	-	300 Vdc	
Input Frequency	47 Hz	-	63 Hz	
Leakage Current	-	-	0.75 MIU	UL 8750; 277Vac/60Hz
	-	-	0.70 mA	IEC 60598-1; 240Vac/60Hz
Input AC Current	-	-	1.54 A	Measured at 100%load and 120 Vac input.
	-	-	0.83 A	Measured at 100%load and 220 Vac input.
Inrush Current(I ² t)	-	-	3.77 A ² s	At 220Vac input, 25°C cold start, duration=322 μs, 10%Ipk-10%Ipk.
PF	0.9	-	-	At 100-277Vac, 50-60Hz, 65%-100% load (97.5-150W)
THD	-	-	20%	
THD	-	-	10%	At 220-240Vac, 50-60Hz, 75%-100% load (112.5-150W)

Output Specifications

Parameter	Min.	Typ.	Max.	Notes
Output Current Tolerance	-5%loset	-	5%loset	At 100%load condition
Output Current Setting(loset) Range				
EUM-150S070Ex	53 mA	-	700 mA	
EUM-150S105Ex	70 mA	-	1050 mA	
EUM-150S150Ex	105 mA	-	1500 mA	
EUM-150S210Ex	140 mA	-	2100 mA	
EUM-150S420Ex	268 mA	-	4200 mA	
Output Current Setting Range with Constant Power				
EUM-150S070Ex	530 mA	-	700 mA	
EUM-150S105Ex	700 mA	-	1050 mA	
EUM-150S150Ex	1050 mA	-	1500 mA	
EUM-150S210Ex	1400 mA	-	2100 mA	
EUM-150S420Ex	2680 mA	-	4200 mA	
Total Output Current Ripple (pk-pk)	-	5%Iomax	10%Iomax	At 100%load condition. 20 MHz BW
Output Current Ripple at < 200 Hz (pk-pk)	-	2%Iomax	-	At 100%load condition. Only this component of ripple is associated with visible flicker.
Startup Overshoot Current	-	-	10%Iomax	At 100%load condition
No Load Output Voltage				
EUM-150S070Ex	-	-	350 V	
EUM-150S105Ex	-	-	270 V	
EUM-150S150Ex	-	-	180 V	
EUM-150S210Ex	-	-	120 V	
EUM-150S420Ex	-	-	70 V	

Output Specifications (Continued)

Parameter	Min.	Typ.	Max.	Notes
Line Regulation	-	-	±0.5%	Measured at 100%load
Load Regulation	-	-	±3.0%	
Turn-on Delay Time	-	-	0.5 s	Measured at all dimming modes except DALI-2, and 120-277Vac input, 65%-100%Load
	-	-	1.0 s	Measured at DALI-2 dimming mode, and 120-277Vac input, 65%-100% Load
Temperature Coefficient of loset	-	0.03%/°C	-	Case temperature = 0°C~Tc max

General Specifications

Parameter	Min.	Typ.	Max.	Notes
Efficiency at 120 Vac input:				
EUM-150S070Ex				
Io= 530 mA	90.0%	92.0%	-	
Io= 700 mA	90.0%	92.0%	-	
EUM-150S105Ex				
Io= 700 mA	89.0%	91.0%	-	
Io=1050 mA	89.5%	91.5%	-	
EUM-150S150Ex				
Io=1050 mA	89.0%	91.0%	-	Measured at 100% load and steady-state temperature in 25°C ambient; (Efficiency will be about 2.0% lower if measured immediately after startup.)
Io=1500 mA	89.0%	91.0%	-	
EUM-150S210Ex				
Io=1400 mA	88.0%	90.0%	-	
Io=2100 mA	88.5%	90.5%	-	
EUM-150S420Ex				
Io=2680 mA	87.5%	89.5%	-	
Io=4200 mA	87.0%	89.0%	-	
Efficiency at 220 Vac input:				
EUM-150S070Ex				
Io= 530 mA	92.0%	94.0%	-	Measured at 100% load and steady-state temperature in 25°C ambient; (Efficiency will be about 2.0% lower if measured immediately after startup.)
Io= 700 mA	92.0%	94.0%	-	
EUM-150S105Ex				
Io= 700 mA	91.0%	93.0%	-	
Io=1050 mA	91.5%	93.5%	-	
EUM-150S150Ex				
Io=1050 mA	91.5%	93.5%	-	
Io=1500 mA	91.0%	93.0%	-	
EUM-150S210Ex				
Io=1400 mA	90.5%	92.5%	-	
Io=2100 mA	91.0%	93.0%	-	
EUM-150S420Ex				
Io=2680 mA	90.0%	92.0%	-	
Io=4200 mA	89.5%	91.5%	-	

General Specifications (Continued)

Parameter	Min.	Typ.	Max.	Notes
Efficiency at 277 Vac input: EUM-150S070Ex				Measured at 100% load and steady-state temperature in 25°C ambient; (Efficiency will be about 2.0% lower if measured immediately after startup.)
I _o = 530 mA	92.0%	94.0%	-	
I _o = 700 mA	92.0%	94.0%	-	
EUM-150S105Ex				
I _o = 700 mA	91.5%	93.5%	-	
I _o =1050 mA	92.0%	94.0%	-	
EUM-150S150Ex				
I _o =1050 mA	92.0%	94.0%	-	
I _o =1500 mA	91.5%	93.5%	-	
EUM-150S210Ex				
I _o =1400 mA	91.0%	93.0%	-	
I _o =2100 mA	91.0%	93.0%	-	
EUM-150S420Ex				
I _o =2680 mA	90.0%	92.0%	-	
I _o =4200 mA	90.0%	92.0%	-	
Power Monitoring Accuracy	-1%	-	1%	Measured at 220Vac input and 100%Load
Standby Power	-	-	0.5 W	Measured at 230Vac/50Hz; Dimming off
MTBF	-	287,000 Hours	-	Measured at 220Vac input, 80%Load and 25°C ambient temperature (MIL-HDBK-217F)
Lifetime	-	117,000 Hours	-	Measured at 220Vac input, 80%Load and 70°C case temperature; See lifetime vs. T _c curve for the details
Operating Case Temperature for Safety T _{c_s}	-40°C	-	+90°C	
Operating Case Temperature for Warranty T _{c_w}	-40°C	-	+80°C	Case temperature for 5 years warranty Humidity: 10% RH to 95% RH
Storage Temperature	-40°C	-	+85°C	Humidity: 5%RH to 95%RH
Dimensions Inches (L × W × H) Millimeters (L × W × H)	6.34 × 2.52 × 1.44 161 × 64 × 36.5			With mounting ear 7.01 × 2.52 × 1.44 178 × 64 × 36.5
Net Weight	-	790g	-	

Dimming Specifications

Parameter	Min.	Typ.	Max.	Notes
DA, DA High Level	9.5 V	16 V	22.5 V	
DA, DA Low Level	-6.5 V	0 V	6.5 V	
DA, DA Current	0 mA	-	2 mA	

Dimming Specifications (Continued)

Parameter		Min.	Typ.	Max.	Notes
Dimming Output Range	EUM-150S070Ex EUM-150S105Ex EUM-150S150Ex EUM-150S210Ex EUM-150S420Ex	10%loset	-	loset	530 mA ≤ loaset ≤ 700 mA 700 mA ≤ loaset ≤ 1050 mA 1050 mA ≤ loaset ≤ 1500 mA 1400 mA ≤ loaset ≤ 2100 mA 2680 mA ≤ loaset ≤ 4200 mA
	EUM-150S070Ex EUM-150S105Ex EUM-150S150Ex EUM-150S210Ex EUM-150S420Ex	53 mA 70 mA 105 mA 140 mA 268 mA	-	loset	53 mA ≤ loaset ≤ 530mA 70 mA ≤ loaset < 700 mA 105 mA ≤ loaset < 1050 mA 140 mA ≤ loaset < 1400 mA 268 mA ≤ loaset < 2680 mA

Safety & EMC Compliance

Safety Category	Standard
UL/CUL	UL 8750,CAN/CSA-C22.2 No. 250.13
ENEC	EN 61347-1 ⁽¹⁾ , EN 61347-2-13
UKCA	BS EN 61347-1 ⁽¹⁾ , BS EN 61347-2-13 BS EN 301 489-1 BS EN 301 489-3 BS EN 300 330 BS EN 62479/BS EN 50663/BS EN 50665/BS EN 50364
CE	EN 61347-1 ⁽¹⁾ , EN 61347-2-13 EN 301 489-1 EN 301 489-3 EN 300 330 EN 62479/EN 50663/EN 50665/EN 50364
CB	IEC 61347-1 ⁽¹⁾ , IEC 61347-2-13
CCC	GB 19510.1, GB 19510.14
KS	KS C 7655
BIS	IS 15885(Part2/Sec13)
Performance	Standard
ENEC	EN IEC 62384
EMI Standards	Notes
BS EN/EN IEC 55015/GB/T 17743 ⁽²⁾	Conducted emission Test &Radiated emission Test
BS EN/EN IEC 61000-3-2/GB 17625.1	Harmonic current emissions
BS EN/EN 61000-3-3	Voltage fluctuations & flicker
FCC Part 15 ⁽²⁾	ANSI C63.4 Class B
	This device complies with Part 15 of the FCC Rules. Operation is subject to the following two conditions: [1] this device may not cause harmful interference, and [2] this device must accept any interference received, including interference that may cause undesired Operation.

Safety & EMC Compliance (Continued)

EMS Standards	Notes
BS EN/EN 61000-4-2	Electrostatic Discharge (ESD): 8 kV air discharge, 4 kV contact discharge
BS EN/EN 61000-4-3	Radio-Frequency Electromagnetic Field Susceptibility Test-RS
BS EN/EN 61000-4-4	Electrical Fast Transient / Burst-EFT
BS EN/EN 61000-4-5	Surge Immunity Test: AC Power Line: Differential Mode 6 kV, Common Mode 10 kV
BS EN/EN 61000-4-6	Conducted Radio Frequency Disturbances Test-CS
BS EN/EN 61000-4-8	Power Frequency Magnetic Field Test
BS EN/EN 61000-4-11	Voltage Dips
BS EN/EN 61547	Electromagnetic Immunity Requirements Applies To Lighting Equipment
DALI-2 Standards	Notes
DALI-2 ⁽³⁾	IEC 62386-101, 102 & 207

- Notes:** (1) EE models meet the requirements for EN/BS EN/IEC 61347-1(Class II), when the driver is energized, the allowed leakage current is perceptible but harmless.
 (2) This LED driver meets the EMI specifications above, but EMI performance of a luminaire that contains it depends also on the other devices connected to the driver and on the fixture itself.
 (3) DALI Parts: 101, 102, 207, 251, 252, 253.

Derating

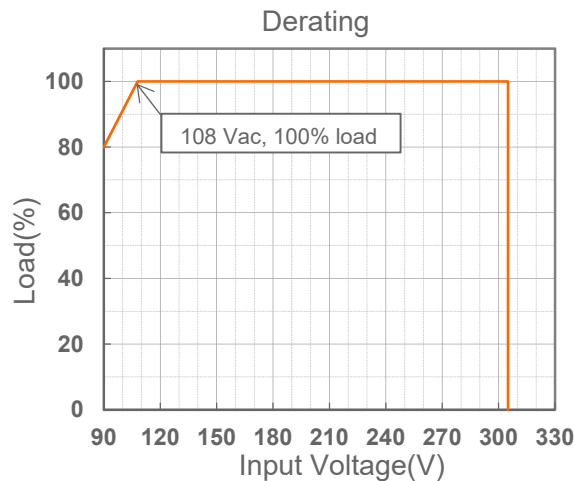

Lifetime vs. Case Temperature

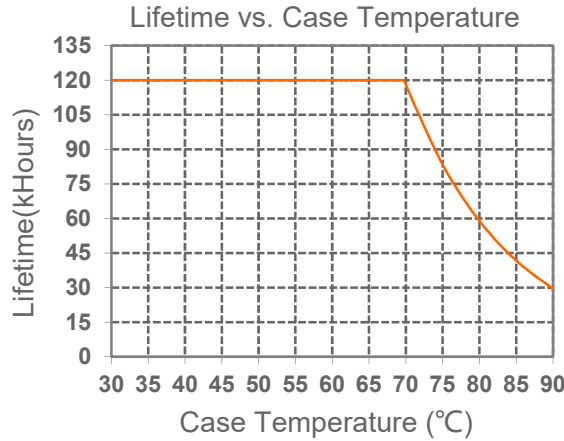

Inrush Current Waveform

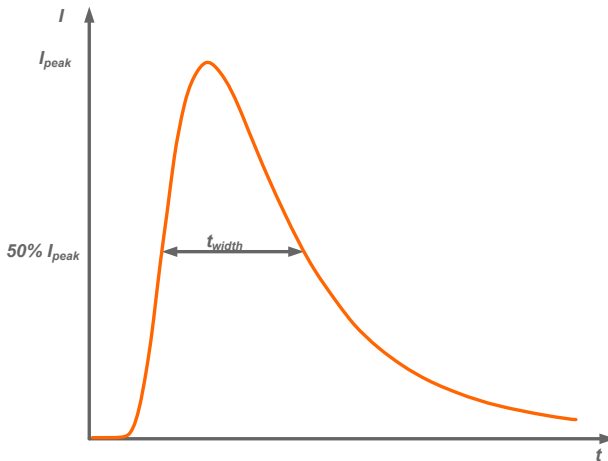

Input AC Voltage	I_{peak}	t_{width} (@ 50% I_{peak})
220 Vac	125 A	122 μ s

Efficiency vs. Load

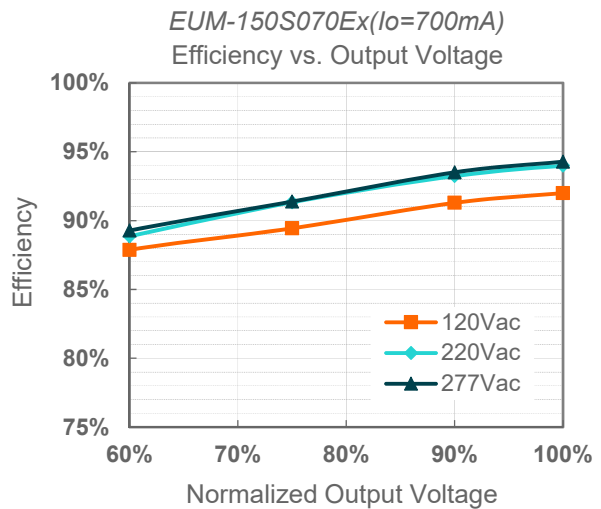
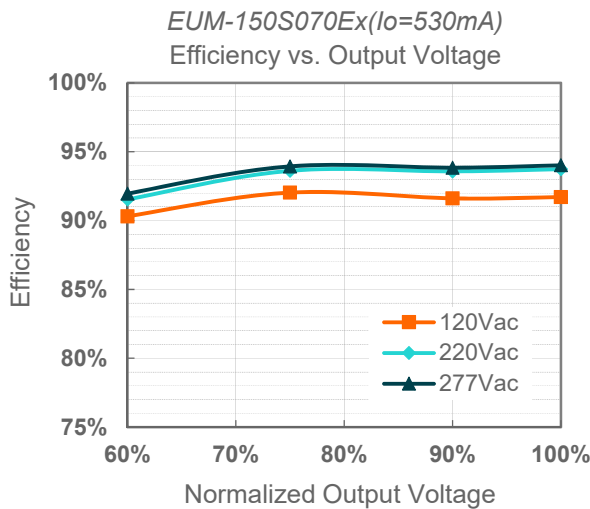

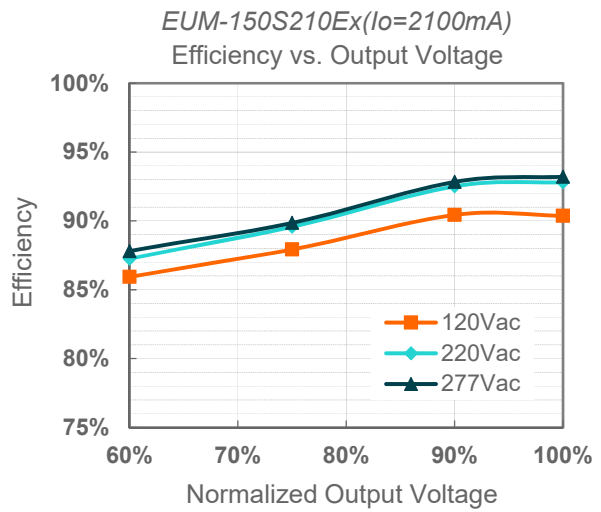
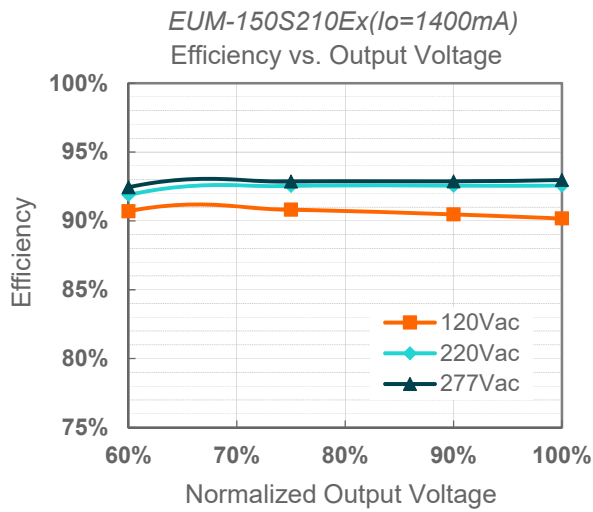
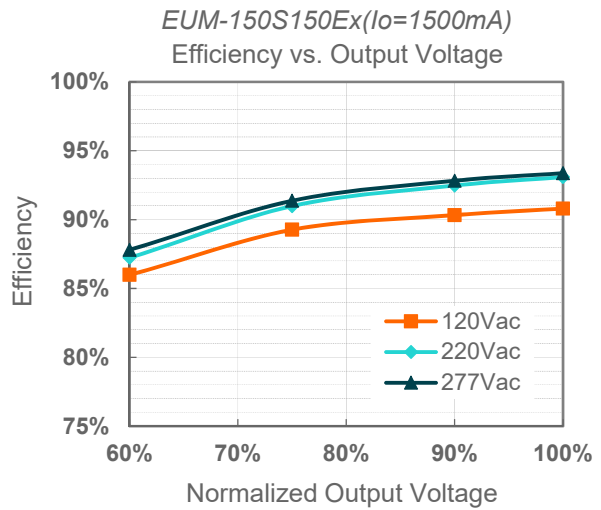
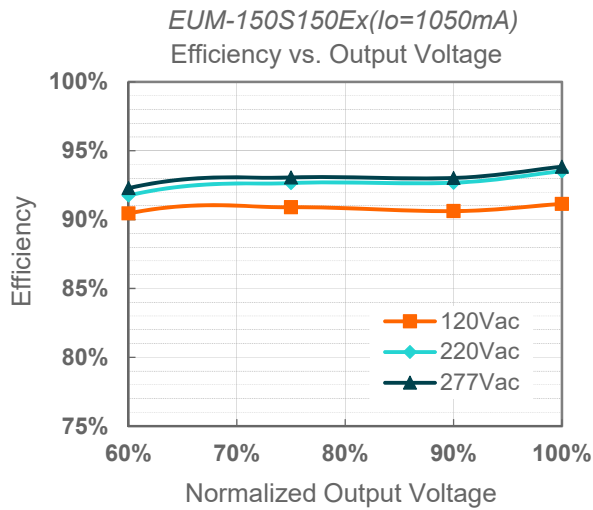
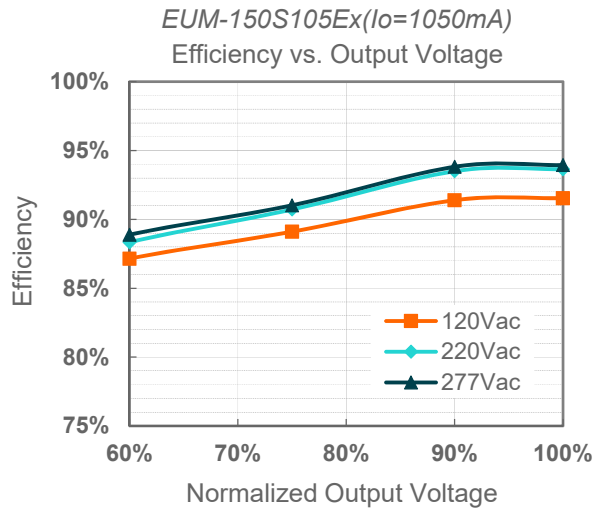
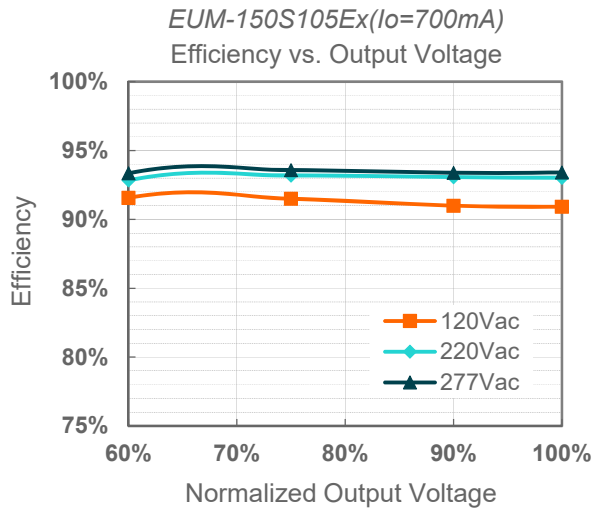

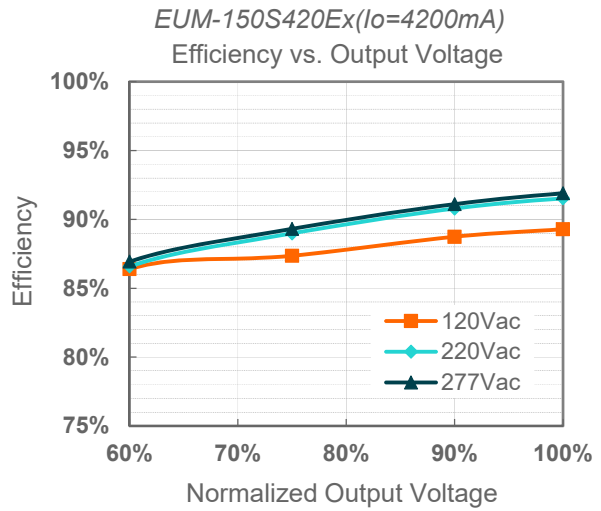
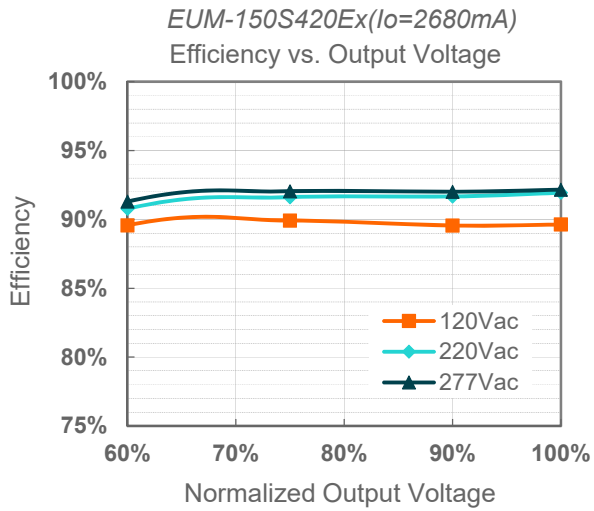

Power Factor

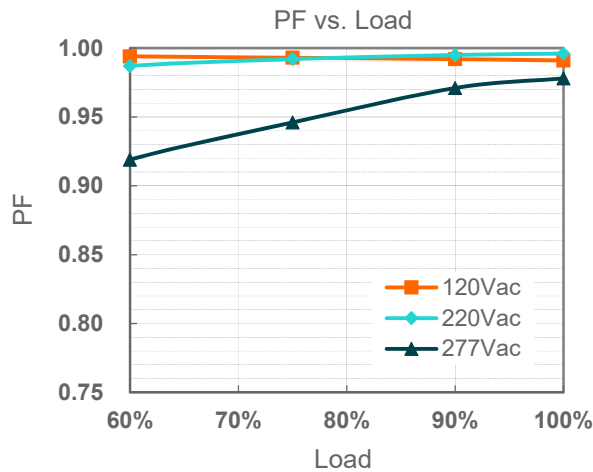

Total Harmonic Distortion

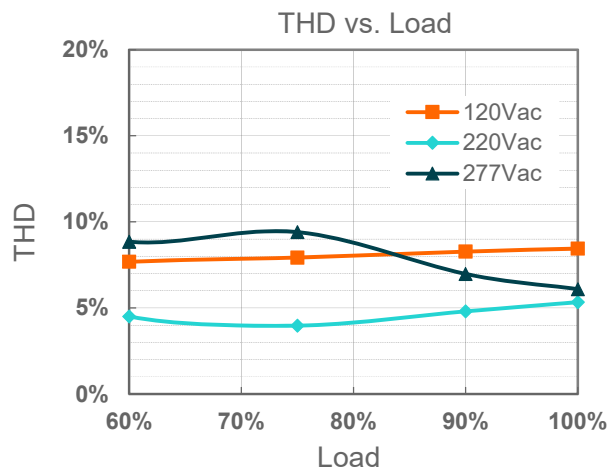

Protection Functions

Parameter		Min.	Typ.	Max.	Notes
Over Voltage Protection		Limits output voltage at no load and in case the normal voltage limit fails.			
Short Circuit Protection		Auto Recovery. No damage will occur when any output is short circuited. The output shall return to normal when the fault condition is removed.			
Over Temperature Protection		Decreases output current, returning to normal after over temperature is removed.			
Input Under Voltage Protection (IUVP)	Input Under Voltage Protection	70 Vac	80 Vac	90 Vac	Turn off the output when the input voltage falls below protection voltage.
	Input Under Voltage Recovery	75 Vac	85 Vac	95 Vac	Auto Recovery. The driver will restart when the input voltage exceeds recovery voltage.
Input Over Voltage Protection (IOVP)	Input Over Voltage Protection	310 Vac	320 Vac	330 Vac	Turn off the output when the input voltage exceeds protection voltage.
	Input Over Voltage Recovery	300 Vac	310 Vac	320 Vac	Auto Recovery. The driver will restart when the input voltage falls below recovery voltage.
	Max. of Input Over Voltage	-	-	350 Vac	The driver can survive stabilized input over voltage conditions up to 350Vac for a total of 8 hours.

● Input Under Voltage Protection Diagram

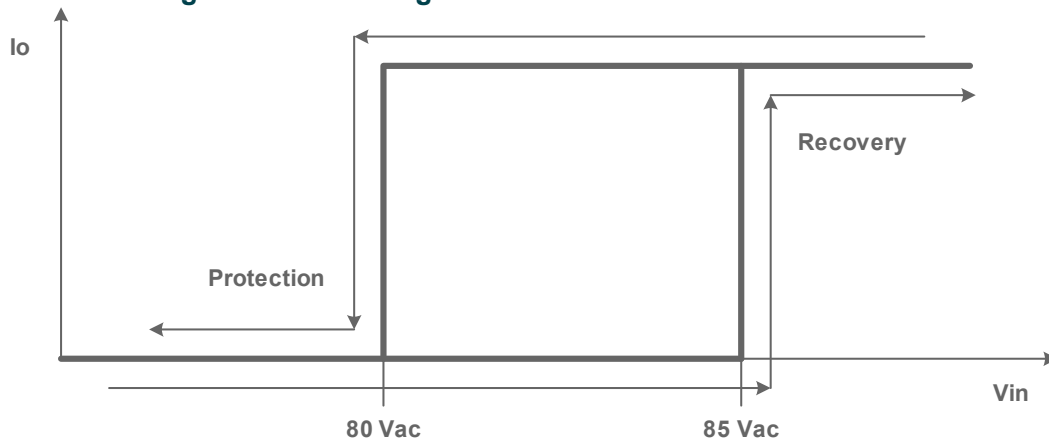

● Input Over Voltage Protection Diagram

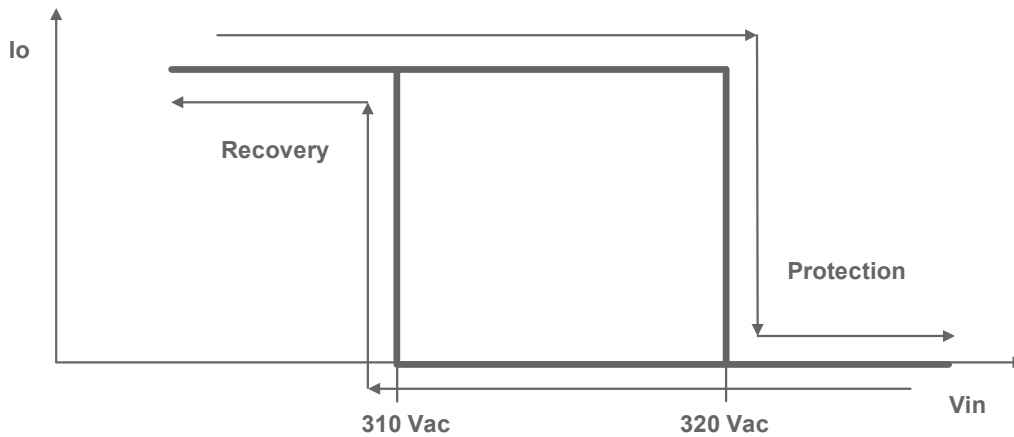

Dimming

● DALI-2 Dimming

The recommended implementation of the dimming control is provided below.

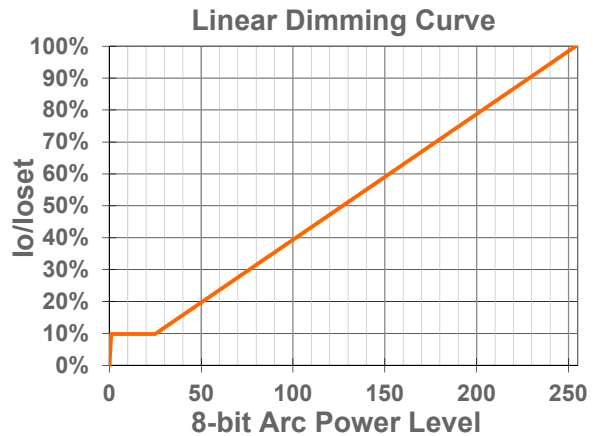
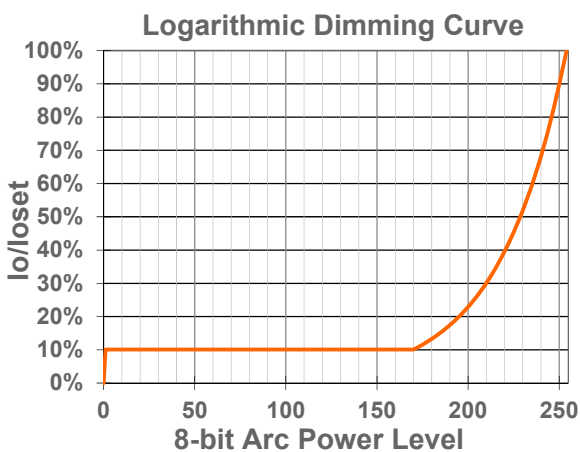
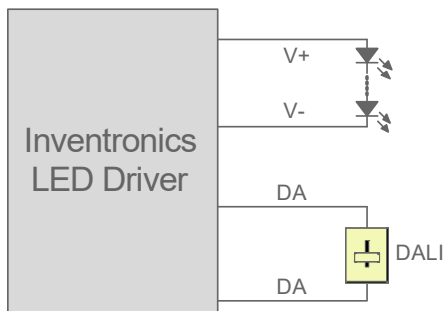

Implementation: DALI-2 Dimming

● Time Dimming

Time dimming control includes 3 kinds of modes, they are Self Adapting-Midnight, Self Adapting-Percentage and Traditional Timer.

- **Self Adapting-Midnight:** Automatically adjusts the dimming curve based on the on-time of past two days (if difference <15 minutes), assuming that the center point of the dimming curve is midnight local time.
- **Self Adapting-Percentage:** Automatically adjusts the on-time of each step by a constant percentage = (actual on-time for the past 2 days if difference <15 min) / (programmed on-time from the dimming curve).
- **Traditional Timer:** Follows the programmed timing curve after power on with no changes.

● Output Lumen Compensation

Output Lumen Compensation (OLC) may be used to maintain constant light output over the life of the LEDs by driving them at a reduced current when new, then gradually increasing the drive current over time to counteract LED lumen degradation.

● End Of Life

End-of-Life (EOL) is providing a visual notification to a user that the LED module has reached the end of manufacturer-specified life and that the replacement is recommended. Once active, an indication is given at each power-up of the driver, which the driver indicates this through a lower light output during the first 1 minute before normal operation is continued.

Programming Connection Diagram

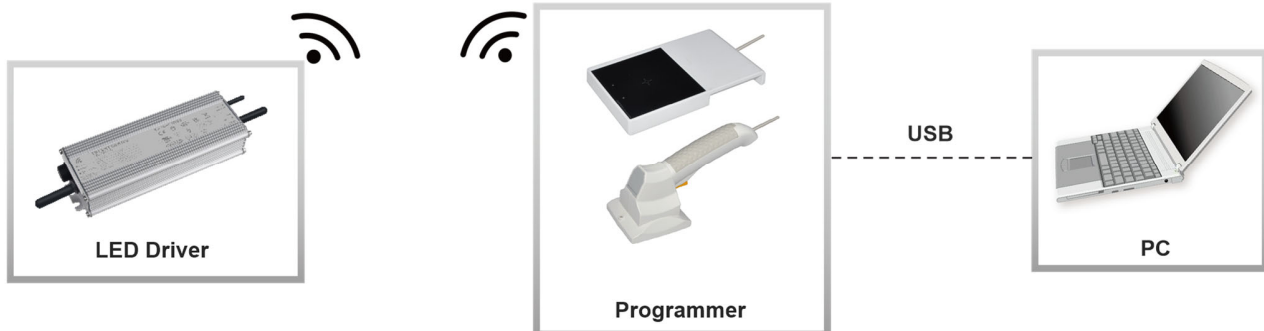

Note: The driver does not need to be powered on during the programming process.

- Please refer to [PRG-NFC-H](#) or [PRG-NFC-D2](#) (Programmer) datasheet for details.

Mechanical Outline

EUM-150SxxxEG

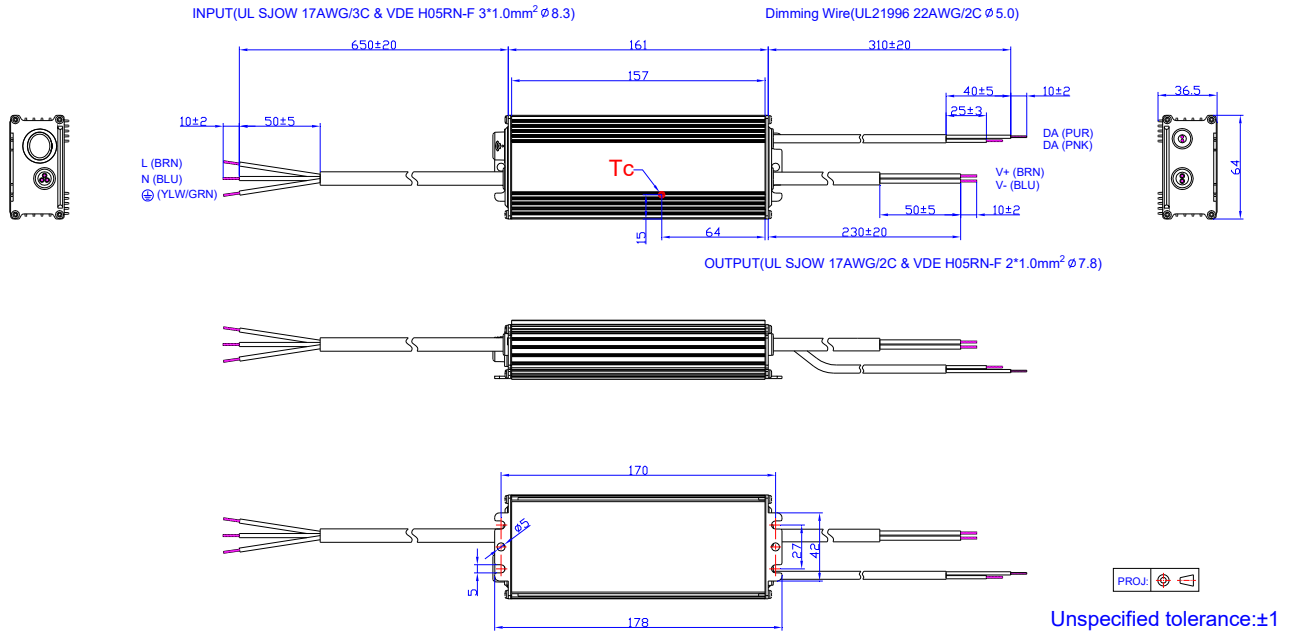

EUM-150SxxxET

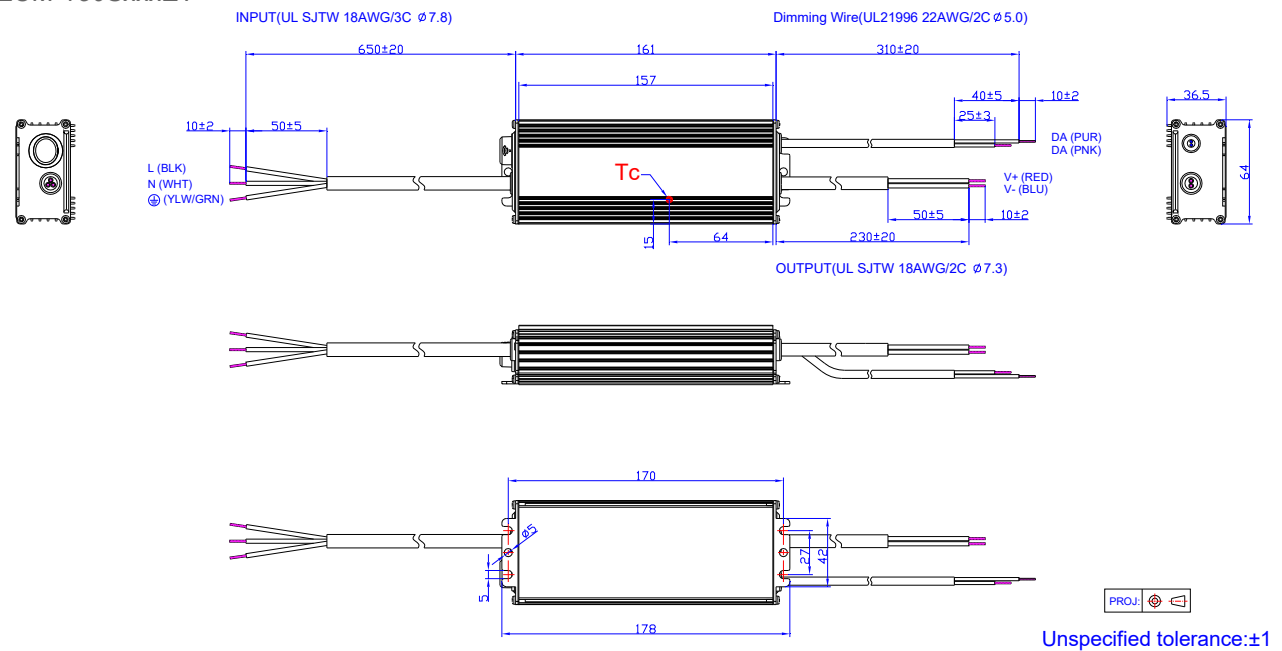

EUM-150SxxxEE

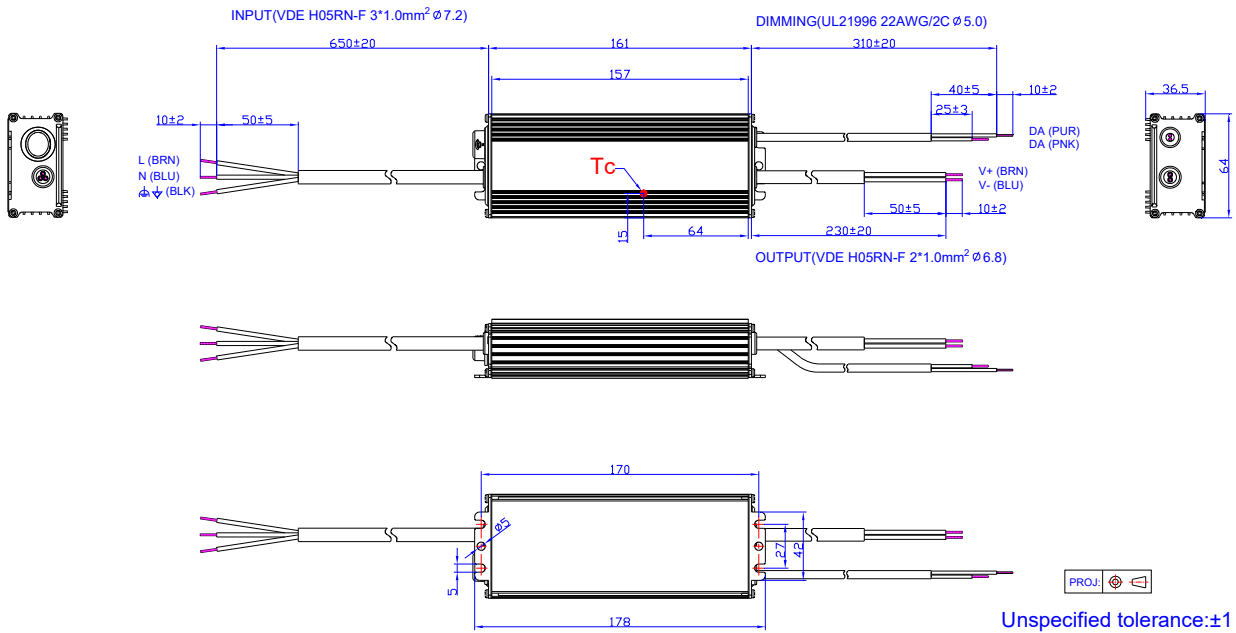

EUM-150SxxxEB

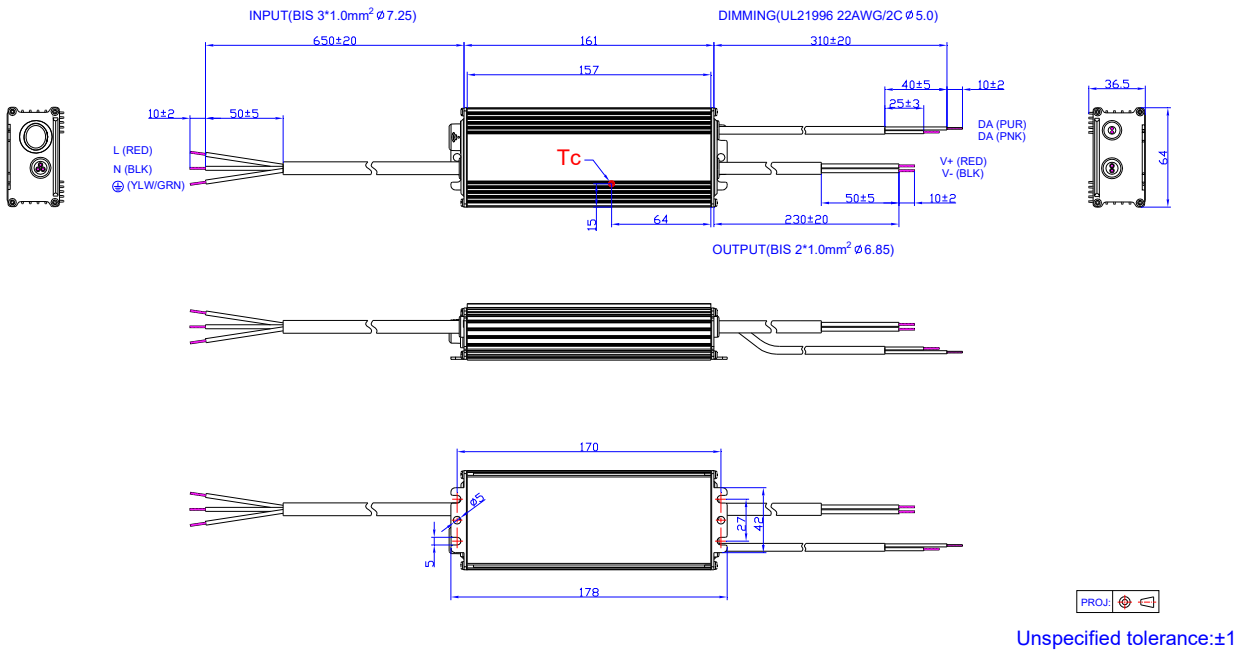

RoHS Compliance

Our products comply with reference to RoHS Directive (EU) 2015/863 amending 2011/65/EU, calling for the elimination of lead and other hazardous substances from electronic products.

Revision History

Change Date	Rev.	Description of Change		
		Item	From	To
2023-01-12	A	Datasheet Release	/	/
2023-03-07	B	Mechanical Outline	/	Updated
2023-08-08	C	Features	/	Updated
		Models	Notes(6)	Updated
		Safety & EMC Compliance	/	Updated
		Dimming	/	Updated
		Mechanical Outline	EUM-150SxxxEE	Added
2024-01-20	D	Format	/	Updated
		BIS logo	/	Added
		Models	/	Updated
		Safety & EMC Compliance	/	Updated
		Inrush Current Waveform	/	Updated
		Dimming	/	Updated
		Mechanical Outline	/	Updated