

Installation Guidelines

The document is to guide how to operate NES-1K8-BC driver for achieving reliable installation.

1. Assembly guideline - Prevention of Moisture Ingress for Outdoor Applications

The driver is intended for use in multiple outdoor lighting applications, such as sports lighting, high mast, etc. Please follow the assembly guidelines below to prevent ingress of moisture and other particles.

Section 1. Assemble end-cap and gland connector

It is critical to use appropriate tools to fix the screws and the glands, please refer to table below for the recommendation. Meanwhile, the 'body nut' of the gland should be secured during tightening gland caps.

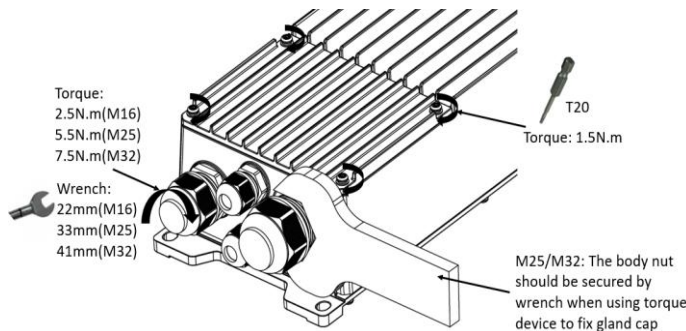

Items	Torque	Tool
Screws	1.5 N.m	T20
M16	2.5 N.m	22mm
M25	5.5 N.m	33mm
M32	7.5 N.m	41mm

Section 2. Assemble cable on the driver

a. Dis-assemble end-cap and gland connector

Please follow the operation guideline in section 1.

b. Assemble and Dis-assemble wire leads from terminals

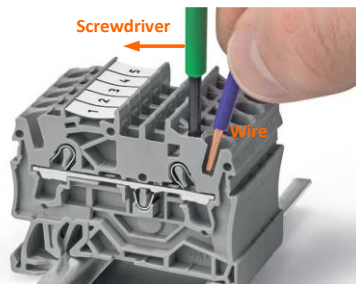

WAGO 210-720, or Equivalent
(Blade Dimension: 3.5 * 0.5 mm)



c. Re-assemble end-cap and gland connector

Ensure the white gasket below is properly fitted in the groove of the upper lid, and please change this white gasket immediately if it is worn-out to achieve reliable sealing performance. The four screws are fastened by tool in a diagonal sequence. Please also follow the operation guideline in section 1.

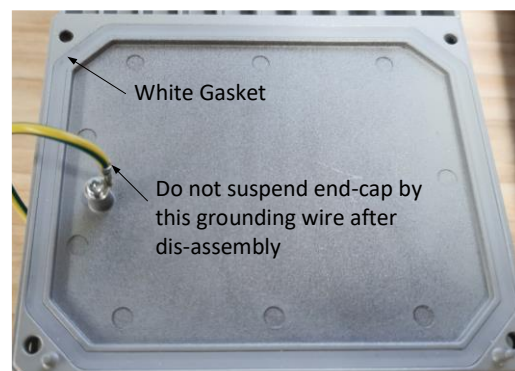

2. Installation notes

a. Recommended cable spec for the gland connectors

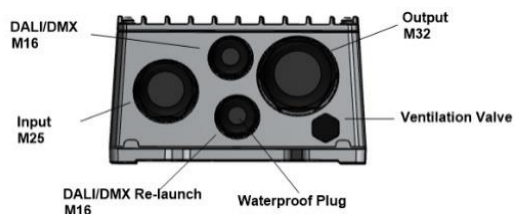

Connection	Cable Gland	Toque (N·m)	Cable Diameter (mm)	Cable AWG	Cable Section (mm ²)
AC Input	M25	5.5	13-18	15-12	1.5-2.5
DC Output	M32	7.5	15-21	15-12	1.5-2.5
DALI/DMX	M16	2.5	5-10	18-12	0.75-2.5
DALI/DMX Re-launch	M16	2.5	5-10	18-12	0.75-2.5

Smaller sealings are available on request

b. Output wires size recommendation

The recommended cross-sectional area of the wires is depicted below for reducing voltage drop, and the other wires size can be also used after system evaluation

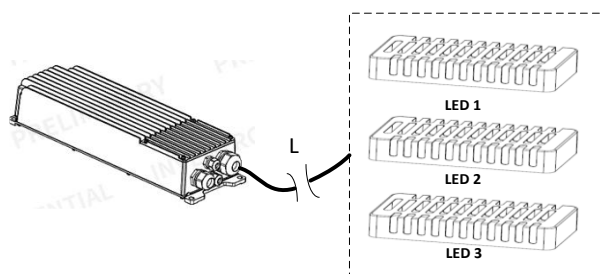

L < 100m: Wire Size 1.5 mm²
 100 m < L < 300m: Wire Size 2.5 mm²

c. Functions definition for different terminals



The NES-1K8T210BC supports a 'common anode' (common Vo+) connection.

d. Installation and Thermal Management

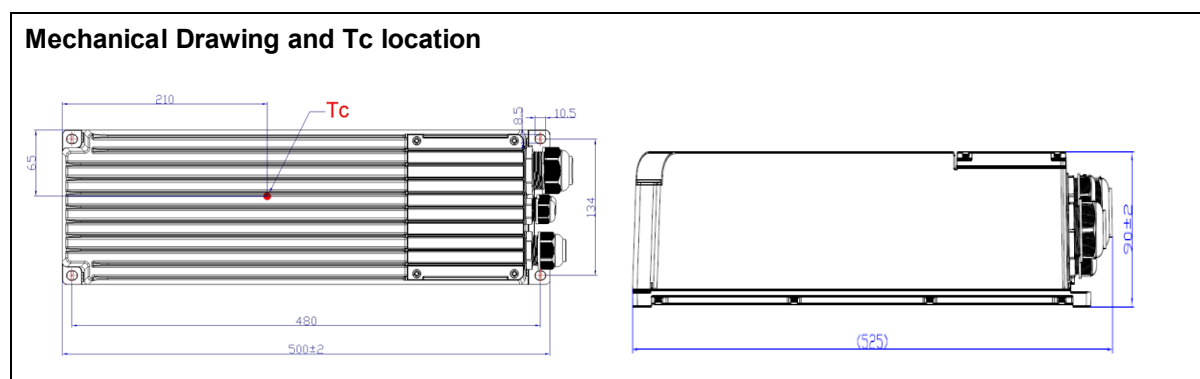

Installation Orientation and Thermal Management

The driver should be installed flatwise, and the distance between drivers and side walls is recommended as shown in drawing, the thermal testing suggested to be evaluated under real installation and application conditions, and ensure its case temperature is lower than 80C warranty T_c

A painted cabinet enclosure suggested to be selected with high reflectance ratio to reduce solar radiant heat.

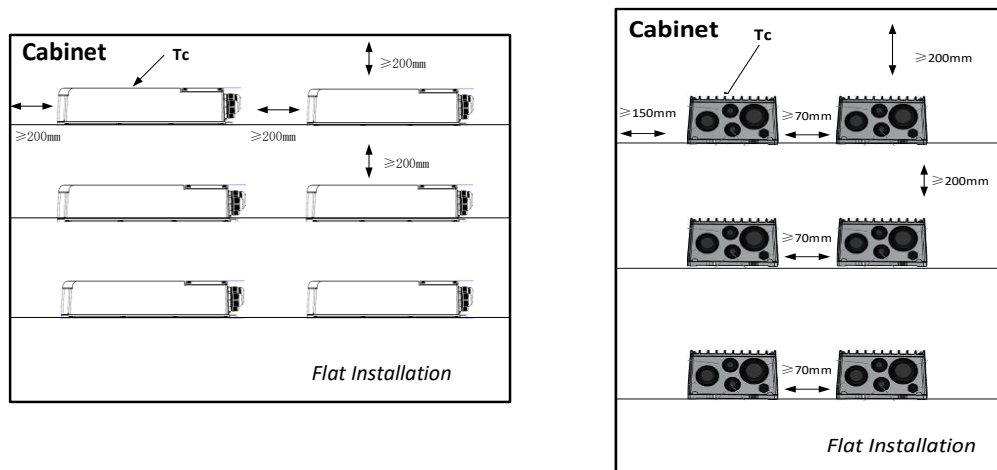

e. **Other notes** please refer to Inventronics standard installation manual below and datasheet

The installation will be executed by a qualified electrician, and operation only be done without energizing driver

<https://www.inventronics-co.com/wp-content/uploads/2018/09/Installation-Instructions%EF%BC%9ALED-Drivers.pdf>

3. The isolation levels between circuits

	AC Input	DC Output	Dimming (SELV)	Housing
AC Input	/	No isolation	Double	Basic
DC Output	No isolation	/	Double	Basic
Dimming (SELV)	Double	Double	/	Basic
Housing	Basic	Basic	Basic	/

The required test voltages to comply with the Electric Strength test (a.k.a. the 'hi-pot test') of (EN IEC 60598-1:2021, §10.2.2):

	AC Input	DC Output	Dimming (SELV)	Housing
AC Input	/	No isolation	3660Vac	1830Vac
DC Output	No isolation	/	4400Vac	2200Vac
Dimming (SELV)	3660Vac	4400Vac	/	1830Vac
Housing	1830Vac	2200Vac	1830Vac	/

4. Numbers of driver per MCB

Power Grid[Vac]	Inrush peak[A]	Duration of 50 % - 50 %[us]
220	5.8	11200
400	12	6800

MCB Type	@220Vac	@400Vac(3-phase)
B6	0	0
B10	0	0
B16	1	1+1+1
B20	1	1+1+1
B25	1	1+1+1
B40	2	2+2+2
C6	0	0
C10	0	0
C16	1	1+1+1
C20	1	1+1+1
C25	2	2+2+2
C40	3	3+3+3

Inventronics is committed to concurrent engineering with our customers to develop the world's most reliable drivers for the toughest applications. Please contact us with any comments, questions, or concerns at: <https://www.inventronics-co.com/technical-support/>.

Disclaimer

This note is for reference only. It is the responsibility of the customer to thoroughly analyze all aspects of the customers' proposed application for the products. The customer is solely responsible for making the final selection of the product(s) to be used and to assure that all performance and safety requirements of the application are satisfied. Inventronics makes no representation or warranty as to the completeness or accuracy of the information contained herein. The products and specifications set forth in this document are subject to change without notice and Inventronics disclaims any and all liability for such changes.