

## Features

- Full Power at Wide Output Current Range (Constant Power)
- Adjustable Output Current (AOC) with NFC
- Isolated 1-10V/3-Timer-Modes Dimmable
- Output Lumen Compensation
- End-of-Life Indicator
- Long Lifetime Over 100K Hours at 75°C Case Temperature
- Input Surge Protection: DM 6kV, CM 10kV
- All-Around Protection: OVP, SCP, OTP
- IP20 Design and Suitable for Outdoor Applications in Luminaires with IP>54
- SELV Output
- Suitable for Luminaires with Protection Class I and II
- Complies with Zhaga Interface Specification Book 13
- 8 Years Warranty



## Description

The EBS-040SxxxDT2 series is a 40W, constant-current, NFC programmable and IP20 rated LED driver that operates from 176-305Vac input with excellent power factor. It was created for many lighting applications including street, tunnel and low bay, etc. The high efficiency of these drivers and better thermal design enable them to run cooler, significantly improving reliability and extending product life. To ensure trouble-free operation, protection is provided against input surge, output over voltage, short circuit, and over temperature.

## Models

| Adjustable Output Current Range(mA) | Full-Power Current Range(mA) <sup>(1)</sup> | Default Output Current(mA) | Output Voltage Range(Vdc) | Max. Output Power(W) | Typical Efficiency <sup>(2)</sup> | Typical Power Factor <sup>(2)</sup> | Model Number <sup>(3)</sup>   |
|-------------------------------------|---|----------------------------|---------------------------|----------------------|-----------------------------------|-------------------------------------|-------------------------------|
| 30-450                              | 300-450                                     | 450                        | 44-133                    | 40                   | 90.5%                             | 0.96                                | EBS-040S045DT2                |
| 45-700                              | 450-700                                     | 700                        | 28-89                     | 40                   | 89.0%                             | 0.96                                | EBS-040S070DT2 <sup>(4)</sup> |
| 70-1050                             | 700-1050                                    | 1050                       | 19-57                     | 40                   | 89.5%                             | 0.96                                | EBS-040S105DT2 <sup>(4)</sup> |

- Notes:** (1) Output current range with constant power at 40W  
 (2) Measured at 100% load and 220Vac input (see below "General Specifications" for details).  
 (3) Certified input voltage range: 200-240Vac  
 (4) SELV Output.

## I-V Operating Area

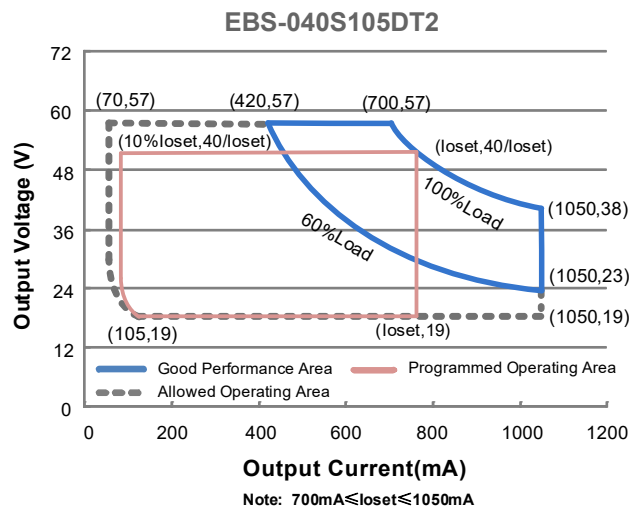
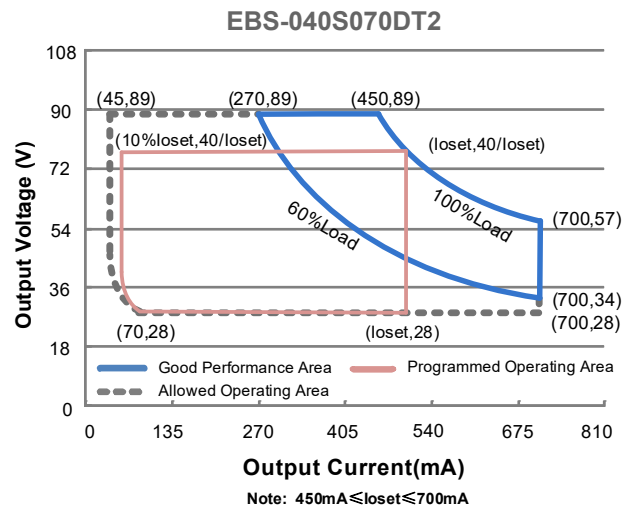
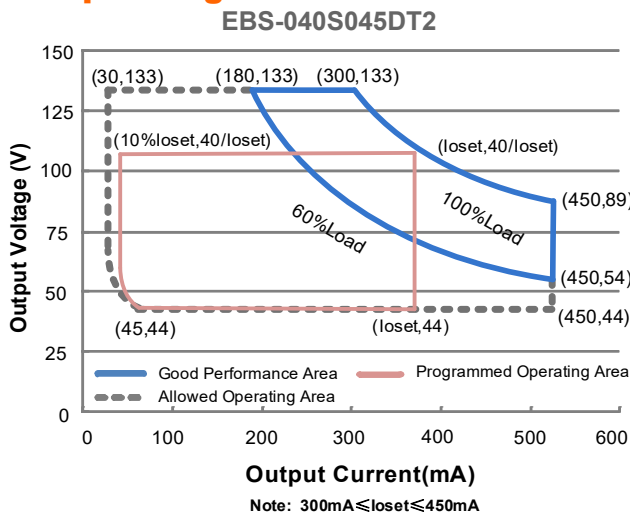

## Input Specifications

| Parameter                        | Min.    | Typ. | Max.                  | Notes   |
|----------------------------------|---------|------|-----------------------|---|
| Input AC Voltage                 | 176 Vac | -    | 305 Vac               |   |
| Input DC Voltage                 | 171 Vdc | -    | 275 Vdc               |   |
| Input Frequency                  | 47 Hz   | -    | 63 Hz                 |   |
| Leakage Current                  | -       | -    | 0.70 mA               | IEC 60598-1; 240Vac/ 60Hz   |
| Input AC Current                 | -       | -    | 0.23 A                | Measured at 100% load and 220 Vac input.  |
| Inrush Current(I <sup>2</sup> t) | -       | -    | 0.82 A <sup>2</sup> s | At 220Vac input, 25°C Cold Start, Duration =440 μs, 10%Ipk-10%Ipk. See Inrush Current Waveform for the details. |

## Input Specifications (Continued)

| Parameter | Min. | Typ. | Max. | Notes  |
|-----------|------|------|------|--|
| PF        | 0.90 | -    | -    | At 200-240Vac, 50-60Hz, 60%-100% Load (24-40W) |
| THD       | -    | -    | 20%  |  |
| THD       | -    | -    | 10%  | At 220-240Vac, 50-60Hz, 70%-100% Load (28-40W) |

## Output Specifications

| Parameter  | Min.     | Typ.     | Max.     | Notes   |
|--|----------|----------|----------|---|
| Output Current Tolerance                         | -5%loset | -        | 5%loset  | At 100% load condition  |
| Output Current Setting(loset) Range              |          |          |          |   |
| EBS-040S045DT2                                   | 30 mA    | -        | 450 mA   |   |
| EBS-040S070DT2                                   | 45 mA    | -        | 700 mA   |   |
| EBS-040S105DT2                                   | 70 mA    | -        | 1050 mA  |   |
| Output Current Setting Range with Constant Power |          |          |          |   |
| EBS-040S045DT2                                   | 300 mA   | -        | 450 mA   |   |
| EBS-040S070DT2                                   | 450 mA   | -        | 700 mA   |   |
| EBS-040S105DT2                                   | 700 mA   | -        | 1050 mA  |   |
| Total Output Current Ripple (pk-pk)              | -        | 5%Iomax  | 10%Iomax | At 100% load condition, 20 MHz BW   |
| Output Current Ripple at < 200 Hz (pk-pk)        | -        | 2%Iomax  | -        | At 100% load condition. Only this component of ripple is associated with visible flicker. |
| Startup Overshoot Current                        | -        | -        | 10%Iomax | At 100% load condition  |
| No Load Output Voltage                           |          |          |          |   |
| EBS-040S045DT2                                   | -        | -        | 170 V    |   |
| EBS-040S070DT2                                   | -        | -        | 115 V    |   |
| EBS-040S105DT2                                   | -        | -        | 75 V     |   |
| Line Regulation                                  | -        | -        | ±1%      | Measured at 100% load   |
| Load Regulation                                  | -        | -        | ±5%      |   |
| Turn-on Delay Time                               | -        | -        | 0.5 s    | Measured at 200-240Vac input, 60%-100% Load   |
| Temperature Coefficient of loset                 | -        | 0.06%/°C | -        | Case temperature = 0°C ~Tc max  |

## General Specifications

| Parameter                    | Min.  | Typ.  | Max. | Notes  |
|------------------------------|-------|-------|------|--|
| Efficiency at 220 Vac input: |       |       |      |  |
| EBS-040S045DT2               |       |       |      | Measured at 100% load and steady-state temperature in 25°C ambient; (Efficiency will be about 2.0% lower if measured immediately after startup.) |
| I <sub>o</sub> = 300 mA      | 88.0% | 90.0% | -    |  |
| I <sub>o</sub> = 450 mA      | 88.5% | 90.5% | -    |  |
| EBS-040S070DT2               |       |       |      |  |
| I <sub>o</sub> = 450 mA      | 86.5% | 88.5% | -    |  |
| I <sub>o</sub> = 700 mA      | 87.0% | 89.0% | -    |  |
| EBS-040S105DT2               |       |       |      |  |
| I <sub>o</sub> = 700 mA      | 87.0% | 89.0% | -    |  |
| I <sub>o</sub> = 1050 mA     | 87.5% | 89.5% | -    |  |

## General Specifications (Continued)

| Parameter  | Min.                                | Typ.          | Max.  | Notes  |
|--|-------------------------------------|---------------|-------|--|
| MTBF   | -                                   | 501,000 hours | -     | Measured at 220Vac input, 80% Load and 25°C ambient temperature (MIL-HDBK-217F)  |
| Lifetime   | -                                   | 104,000 hours | -     | Measured at 220Vac input, 80%Load and 75°C case temperature; See lifetime vs. Tc curve for the details   |
| Operating Case Temperature for Safety Tc_s                 | -40°C                               | -             | +90°C |  |
| Operating Case Temperature for Warranty Tc_w               | -40°C                               | -             | +75°C | Case temperature for 8 years warranty. Please see Inventronics Warranty Statement for complete details. Humidity: 10% RH to 90% RH No condensation |
| Storage Temperature  | -40°C                               | -             | +85°C | Humidity: 5% RH to 95% RH No condensation  |
| Dimensions<br>Inches (L × W × H)<br>Millimeters (L × W ×H) | 5.24 x 3.03 x 1.30<br>133 x 77 x 33 |               |       |  |
| Net Weight   | -                                   | 230 g         | -     |  |

## Dimming Specifications

| Parameter                                    | Min.           | Typ.   | Max.   | Notes   |
|--|----------------|--------|--------|---|
| Absolute Maximum Voltage on the Vdim (+) Pin | -20 V          | -      | 20 V   |   |
| Source Current on Vdim (+)Pin                | 200 uA         | 300 uA | 450 uA | Vdim(+) = 0 V                                   |
| Dimming Output Range                         | EBS-040S045DT2 | -      | loset  | 300 mA ≤ loiset ≤ 450 mA                        |
|  | EBS-040S070DT2 |        |        | 450 mA ≤ loiset ≤ 700 mA                        |
|  | EBS-040S105DT2 |        |        | 700 mA ≤ loiset ≤ 1050 mA                       |
| Dimming Output Range                         | EBS-040S045DT2 | -      | loiset | 30 mA ≤ loiset < 300 mA                         |
|  | EBS-040S070DT2 |        |        | 45 mA ≤ loiset < 450 mA                         |
|  | EBS-040S105DT2 |        |        | 70 mA ≤ loiset < 700 mA                         |
| Recommended Dimming Range for 1-10V          | 1 V            | -      | 9 V    | Default 1-10V dimming mode with positive logic. |

## Safety & EMC Compliance

| Safety Category | Standard   |
|-----------------|--|
| ENEC            | EN 61347-1 <sup>(1)</sup> , EN 61347-2-13  |
| CE              | EN 61347-1 <sup>(1)</sup> , EN 61347-2-13<br>EN 301 489-1<br>EN 301 489-3<br>EN 300 330<br>EN 62479/EN 50663/EN 50665/EN 50364 |
| CB              | IEC 61347-1 <sup>(1)</sup> , IEC 61347-2-13  |
| KS              | KS C 7655  |

## Safety & EMC Compliance (Continued)

| Performance                 | Standard  |
|-----------------------------|---|
| ENEC                        | EN IEC 62384  |
| EMI Standards               | Notes   |
| EN IEC 55015 <sup>(2)</sup> | Conducted emission Test & Radiated emission Test                              |
| EN IEC 61000-3-2            | Harmonic current emissions Class C  |
| EN 61000-3-3                | Voltage Fluctuations & Flicker  |
| EMS Standards               | Notes   |
| EN 61000-4-2                | Electrostatic Discharge (ESD): 8 kV air discharge, 4 kV contact discharge     |
| EN 61000-4-3                | Radio-Frequency Electromagnetic Field Susceptibility Test-RS                  |
| EN 61000-4-4                | Electrical Fast Transient/Burst-EFT   |
| EN 61000-4-5                | Surge Immunity Test: AC Power Line: Differential Mode 6 kV, Common Mode 8 kV  |
| EN 61000-4-6                | Conducted Radio Frequency Disturbances Test-CS                                |
| EN 61000-4-8                | Power Frequency Magnetic Field Test   |
| EN 61000-4-11               | Voltage Dips  |
| EN 61547                    | Surge Immunity Test: AC Power Line: Differential Mode 6 kV, Common Mode 10 kV |
|                             | Electromagnetic Immunity Requirements Applies to Lighting Equipment           |

**Notes:** (1) This product meets the requirements for EN/IEC 61347-1 [Annex O (Double insulation)].

(2) This LED driver meets the EMI specifications above, but EMI performance of a luminaire that contains it depends also on the other devices connected to the driver and on the fixture itself.

## Lifetime vs. Case Temperature

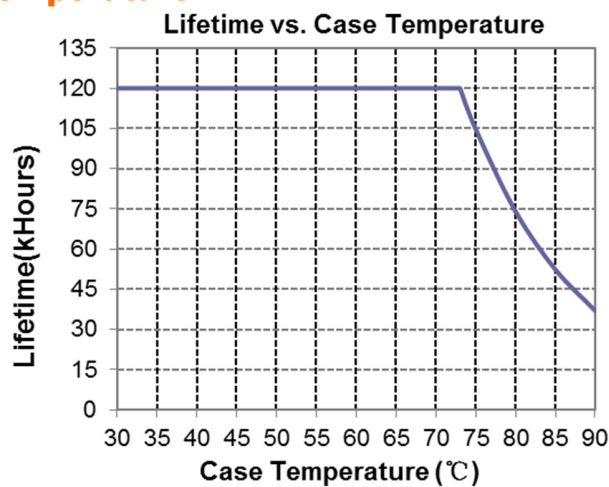

## Inrush Current Waveform

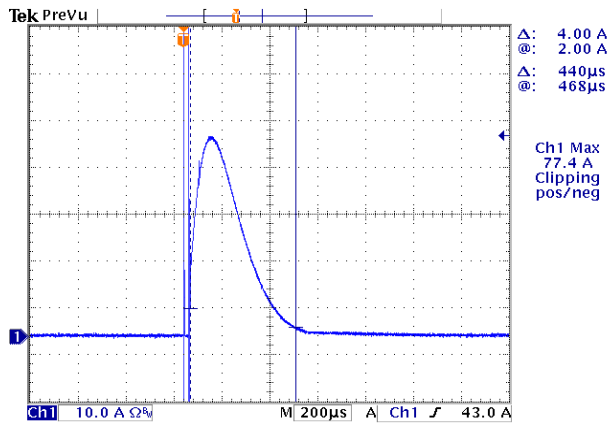

## Efficiency vs. Load

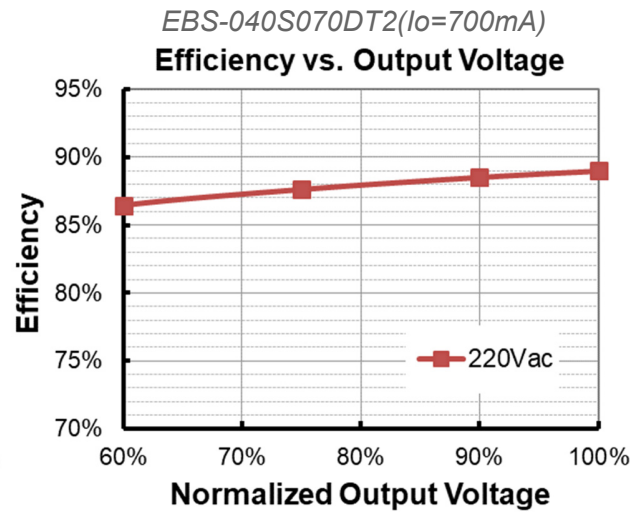
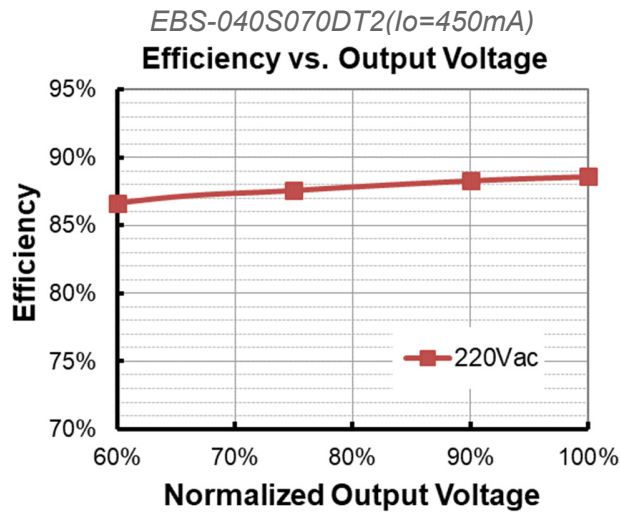
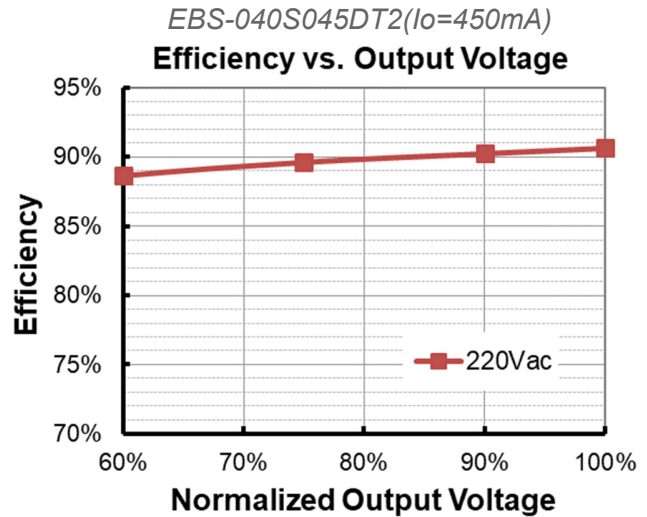
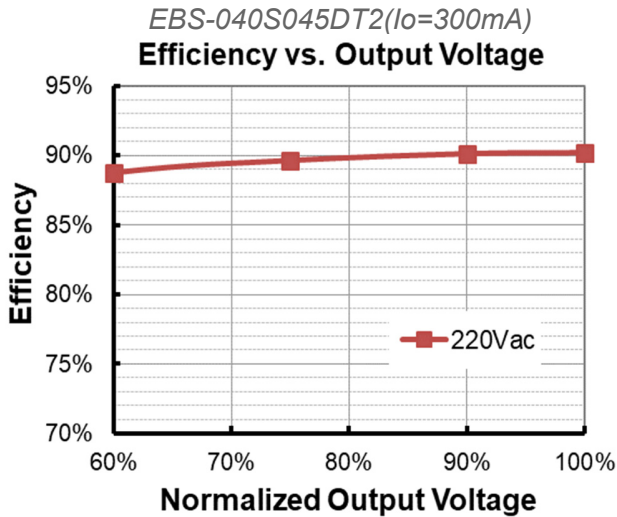

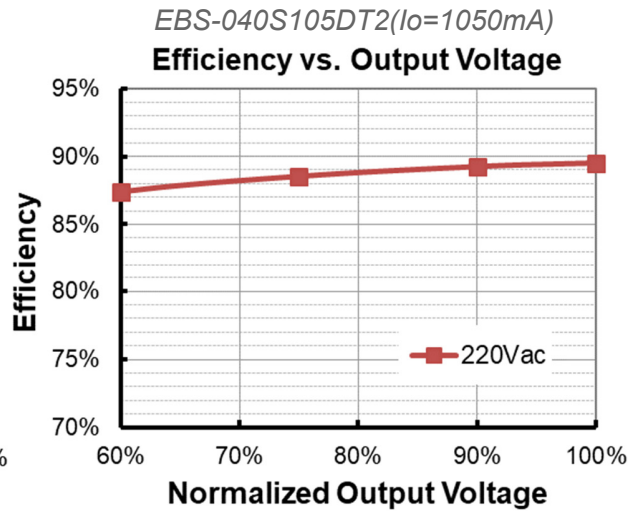
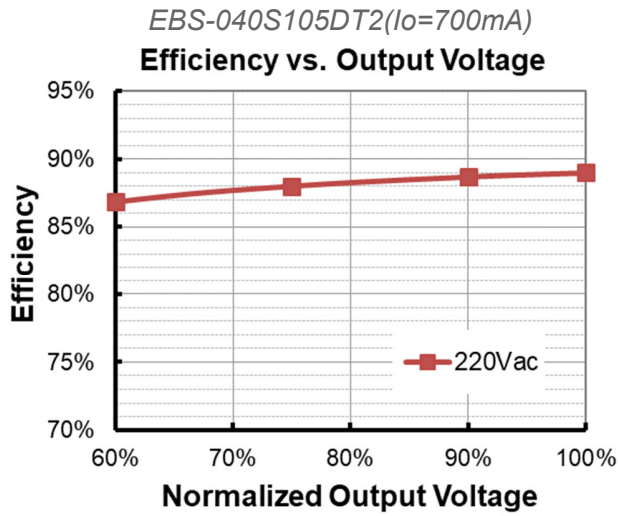

## Power Factor

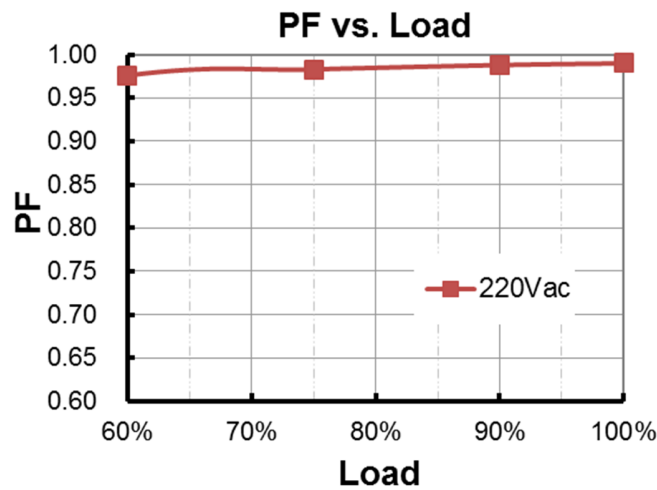

## Total Harmonic Distortion

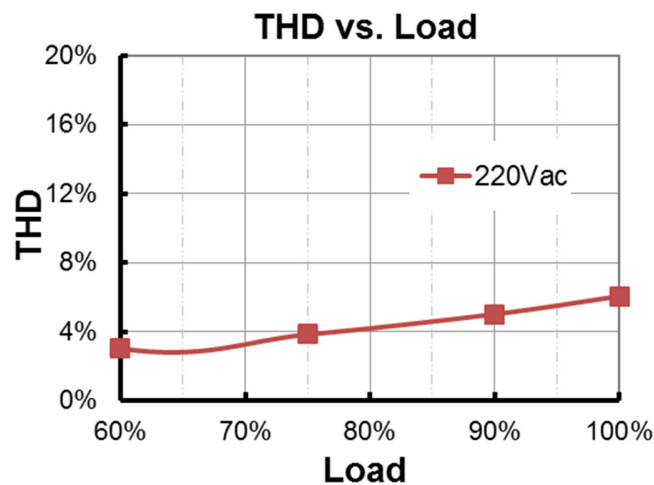

## Protection Functions

| Parameter                    | Min.   | Typ. | Max.    | Notes  |
|------------------------------|--|------|---------|--|
| Over Voltage Protection      | Limits output voltage at no load and in case the normal voltage limit fails.   |      |         |  |
| Short Circuit Protection     | Auto Recovery. No damage will occur when any output is short circuited. The output shall return to normal when the fault condition is removed. |      |         |  |
| Over Temperature Protection  | Decreases output current, returning to normal after over temperature is removed.   |      |         |  |
| Input Over Voltage Withstand | -  | -    | 320 Vac | The driver can survive for 48 hours with input voltage stress of 320Vac. |

## Dimming

### ● 1-10V Dimming

The recommended implementation of the dimming control is provided below.

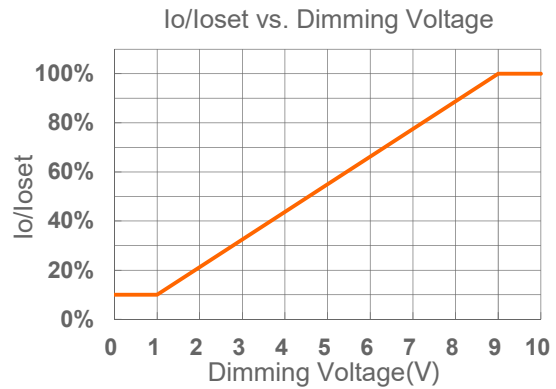
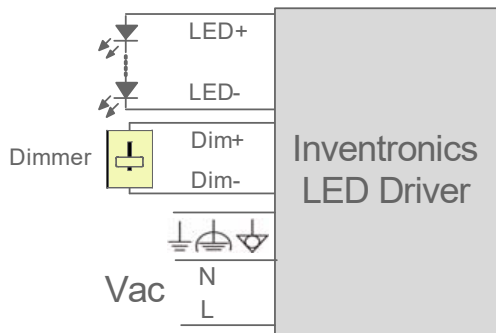

Implementation 1: Positive logic

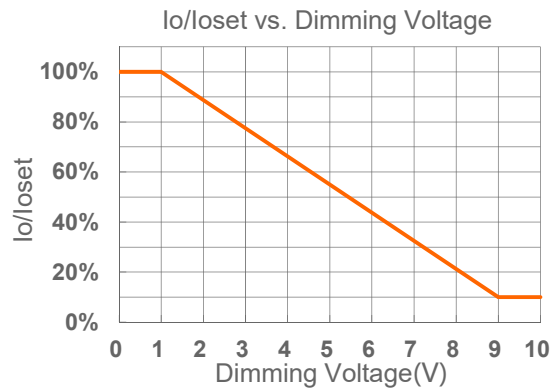
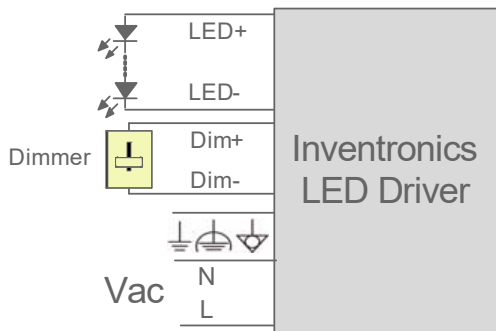

Implementation 2: Negative logic

### Notes:

1. Do NOT connect Dim- to the output V- or V+, otherwise the driver will not work properly.
2. The dimmer can also be replaced by an active 1-10V voltage source signal or passive components like zener.
3. When 1-10V negative logic dimming mode and Dim+ is open, the driver will output minimum current.



## ● Time Dimming

Time dimming control includes 3 kinds of modes, they are Self Adapting-Midnight, Self Adapting-Percentage and Traditional Timer.

- **Self Adapting-Midnight:** Automatically adjusts the dimming curve based on the on-time of past two days (if difference <15 minutes), assuming that the center point of the dimming curve is midnight local time.
- **Self Adapting-Percentage:** Automatically adjusts the on-time of each step by a constant percentage = (actual on-time for the past 2 days if difference <15 min) / (programmed on-time from the dimming curve).
- **Traditional Timer:** Follows the programmed timing curve after power on with no changes.
- **Override Timer:** When the integrated timer is enabled, it is possible to override the dimming mode from 'Timer' into '1-10V' by applying a voltage of 1-10V between DIM+ and DIM-. Once a voltage  $\leq 10.5$  Vdc is detected the output current will coincide with the dimming voltage. By opening the DIM+ and DIM- circuitry, the LED driver will switch again to timer mode. During override, our product continues to count while the timer is being overridden. Once the override is removed, the output current returns to the same point in its timer cycle.

## ● Output Lumen Compensation

Output Lumen Compensation (OLC) may be used to maintain constant light output over the life of the LEDs by driving them at a reduced current when new, then gradually increasing the drive current over time to counteract LED lumen degradation.

## ● End Of Life

End-of-Life (EOL) is providing a visual notification to a user that the LED module has reached the end of manufacturer-specified life and that the replacement is recommended. Once active, an indication is given at each power-up of the driver, which the driver indicates this through a lower light output during the first 1 minute before normal operation is continued.

## Wire Connection Diagram

| Parameter   |                    | Min.                | Typ. | Max.                | Notes   |
|---|--------------------|---------------------|------|---------------------|---|
| L, N,  | Wire Cross-section | 0.4 mm <sup>2</sup> | -    | 1.5 mm <sup>2</sup> | Push-in at 45° angle, solid and stranded wire |
|   |                    | 20 AWG              | -    | 16 AWG              |   |
|   | Strip Length       | 8.5 mm              | -    | 9.5 mm              |   |
| LED+, LED-, Dim+, Dim-  | Wire Cross-section | 0.2 mm <sup>2</sup> | -    | 1.5 mm <sup>2</sup> | Push-in at 45° angle, solid and stranded wire |
|   |                    | 22 AWG              | -    | 16 AWG              |   |
|   | Strip Length       | 8.5 mm              | -    | 9.5 mm              |   |

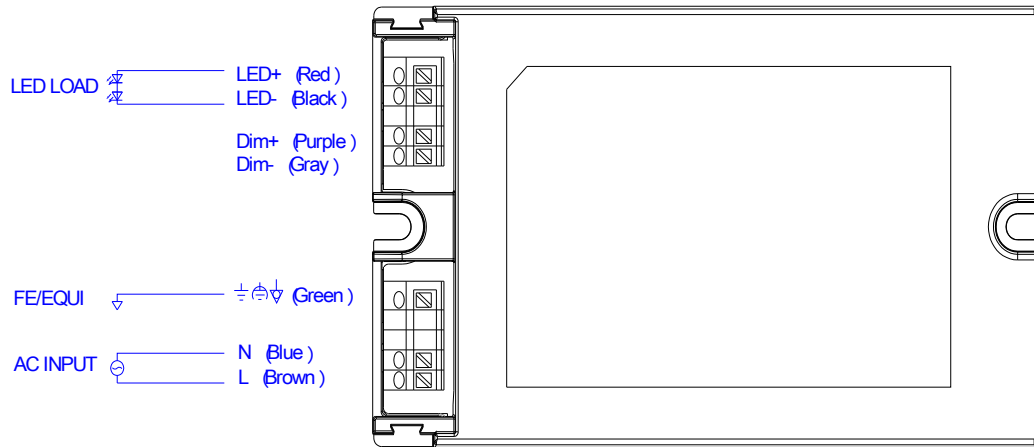

## Programming Connection Diagram

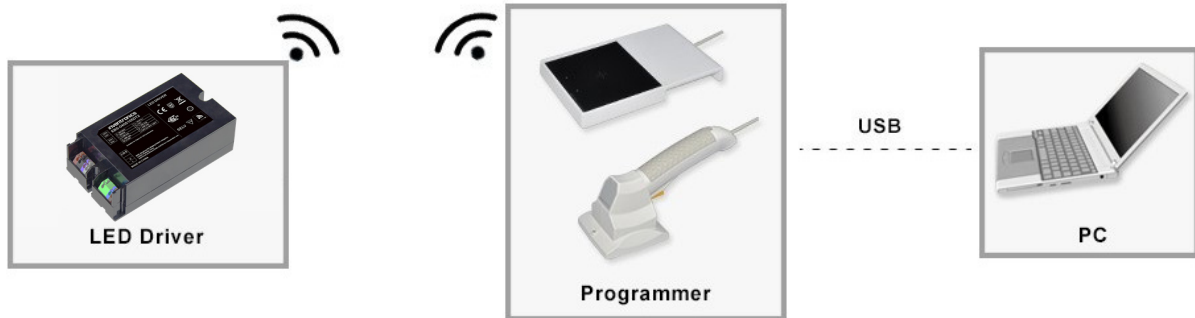

**Note:** The driver does not need to be powered on during the programming process.

- Please refer to [PRG-NFC-H](#) or [PRG-NFC-D2](#) (Programmer) datasheet for details.

## Mechanical Outline

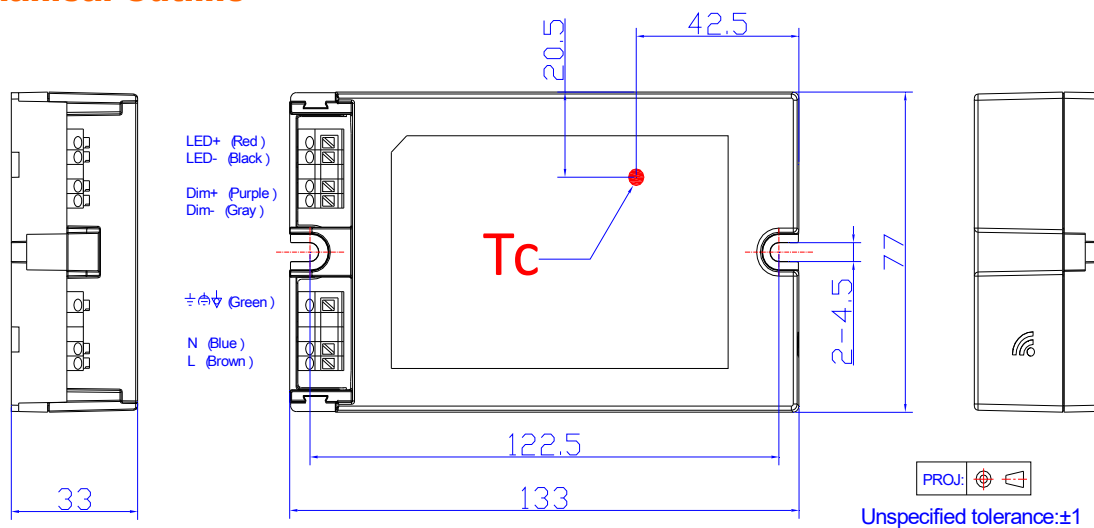

## Optional Cable Clamp

END-CAP02

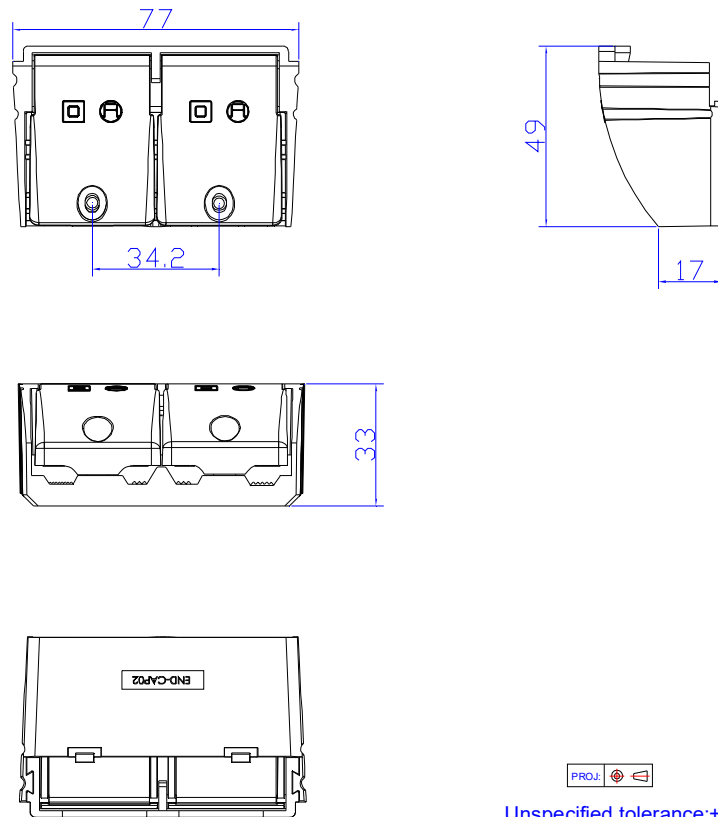

Unspecified tolerance:±1

**Note:** The cable clamp is to be installed with EBS-040SxxxDT2 drivers for independent application. Please refer to [END-CAP02](#) datasheet for details.

## RoHS Compliance

Our products comply with reference to RoHS Directive (EU) 2015/863 amending 2011/65/EU, calling for the elimination of lead and other hazardous substances from electronic products.

## Revision History

| Change Date | Rev. | Description of Change          |             |         |
|-------------|------|--------------------------------|-------------|---------|
|             |      | Item                           | From        | To      |
| 2021-04-08  | A    | Datasheets Release             | /           | /       |
| 2021-04-22  | B    | Models                         | Notes: (2)  | Updated |
|             |      | Input Over Voltage Withstand   | /           | Updated |
| 2021-06-15  | C    | Efficiency vs. Load            | /           | Updated |
| 2021-09-17  | D    | Safety &EMC Compliance         | CE          | Updated |
|             |      | Safety &EMC Compliance         | Performance | Added   |
| 2022-04-15  | E    | Product Photograph             | /           | Updated |
|             |      | UKCA logo                      | /           | Added   |
|             |      | Safety &EMC Compliance         | /           | Updated |
| 2024-08-20  | F    | Format                         | /           | Updated |
|             |      | Product Photograph             | /           | Updated |
|             |      | UKCA/CCC logo                  | /           | Deleted |
|             |      | Models                         | Notes(3)    | Updated |
|             |      | Safety &EMC Compliance         | /           | Updated |
|             |      | Programming Connection Diagram | Note        | Updated |