

Features

- Ultra High Efficiency (Up to 93%)
- Full Power at Wide Output Current Range (Constant Power)
- Thermal Sensing and Protection for LED Module
- 0-10V/PWM/Timer Dimmable (3 Timer Modes)
- Dim-to-Off with Standby Power ≤ 0.5 W
- Always-on Auxiliary Power: 12Vdc, 200mA (Transient Peak Current up to 400mA)
- Output Lumen Compensation
- Long Lifetime Over 100k Hours at 75°C Case Temperature
- Input Surge Protection: DM 6 kV, CM 10 kV
- All-Around Protection: OVP, SCP, OTP
- IP20 Design and Suitable for Outdoor Applications in Luminaires with IP>54
- SELV Output
- Suitable for Luminaires with Protection Class I and II
- Complies with Zhaga Interface Specification Book 13
- 7 Years Warranty



Description

The EBS-080SxxxDTE series is a 80W, constant-current, programmable LED driver that operates from 176-305 Vac input with excellent power factor. Created for many lighting applications including street, tunnel and low bay, it provides a dim-to-off mode with low standby power. The high efficiency of these drivers and better thermal design enable them to run cooler, significantly improving reliability and extending product life. To ensure trouble-free operation, protection is provided against input surge, output over voltage, short circuit, and over temperature of both the driver and the external LED array.

Models

Adjustable Output Current Range(mA)	Full-Power Current Range(mA) ⁽¹⁾	Default Output Current(mA)	Output Voltage Range(Vdc)	Max. Output Power(W)	Typical Efficiency ⁽²⁾	Typical Power Factor ⁽²⁾	Model Number ⁽³⁾
45-700	450-700	530	57-178	80	93.0%	0.98	EBS-080S070DTE
70-1050	700-1050	700	38-114	80	92.5%	0.98	EBS-080S105DTE ⁽⁴⁾

- Notes:** (1) Output current range with constant power at 80W
 (2) Measured at 100% load and 220Vac input (see below “General Specifications” for details).
 (3) Certified voltage range: 200-240Vac or 190-250Vdc (except KS)
 (4) SELV Output.

I-V Operating Area

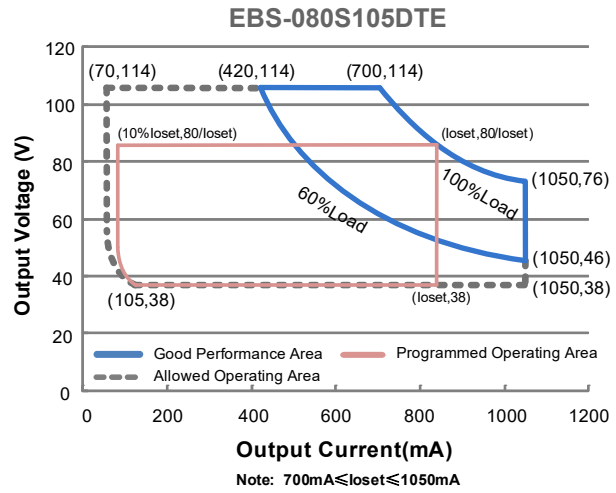
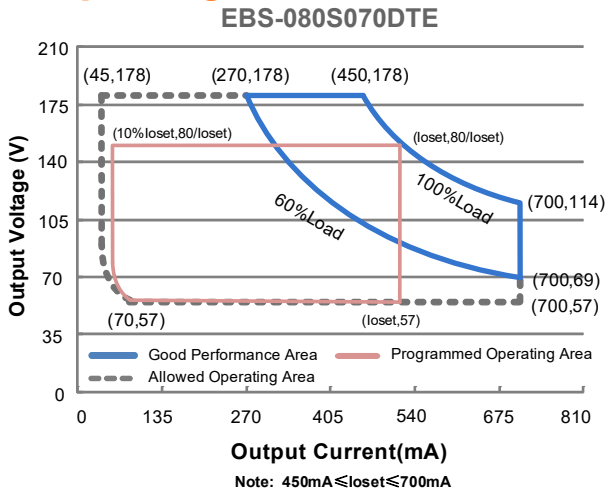

Input Specifications

Parameter	Min.	Typ.	Max.	Notes
Input AC Voltage	176 Vac	-	305 Vac	
Input DC Voltage	190 Vdc	-	250 Vdc	
Input Frequency	47 Hz	-	63 Hz	
Leakage Current	-	-	0.70 mA	IEC 60598-1; 240Vac/ 60Hz
Input AC Current	-	-	0.45 A	Measured at 100% load and 220 Vac input.
Inrush Current(I ² t)	-	-	0.84 A ² s	At 220Vac input, 25°C cold start, duration=576 μs, 10%lpk-10%lpk. See Inrush Current Waveform for the details.
PF	0.90	-	-	At 200-240Vac, 50-60Hz, 60%-100%Load (48-80W)
THD	-	-	20%	
THD	-	-	10%	At 220-240Vac, 50-60Hz, 70%-100%Load (56-80W)

Output Specifications

Parameter	Min.	Typ.	Max.	Notes
Output Current Tolerance	-5%loset	-	5%loset	At 100% load condition
Output Current Setting(Ioset) Range				
EBS-080S070DTE	45 mA	-	700 mA	
EBS-080S105DTE	70 mA	-	1050 mA	
Output Current Setting Range with Constant Power				
EBS-080S070DTE	450 mA	-	700 mA	
EBS-080S105DTE	700 mA	-	1050 mA	
Total Output Current Ripple (pk-pk)	-	5%Iomax	10%Iomax	At 100% load condition, 20 MHz BW

Output Specifications (Continued)

Parameter	Min.	Typ.	Max.	Notes
Output Current Ripple at < 200 Hz (pk-pk)	-	2%I _{omax}	-	At 100% load condition. Only this component of ripple is associated with visible flicker.
Startup Overshoot Current	-	-	10%I _{omax}	At 100% load condition
No Load Output Voltage	-	-	210 V	
EBS-080S070DTE	-	-	119 V	
EBS-080S105DTE	-	-		
Line Regulation	-	-	±0.5%	Measured at 100% load
Load Regulation	-	-	±1.5%	
Turn-on Delay Time	-	-	0.5 s	Measured at 220Vac input, 60%-100% Load
Temperature Coefficient of I _o set	-	0.03%/°C	-	Case temperature = 0°C ~T _c max
12V Auxiliary Output Voltage	10.8 V	12 V	13.2 V	
12V Auxiliary Output Source Current	0 mA	-	200 mA	Return terminal is "Return"
12V Auxiliary Output Transient Peak Current	-	-	400 mA	400mA peak for a maximum duration of 300ms in a 2s period during which time the average should not exceed 200mA.

General Specifications

Parameter	Min.	Typ.	Max.	Notes
Efficiency at 220 Vac input:				
EBS-080S070DTE				Measured at 100% load and steady-state temperature in 25°C ambient; (Efficiency will be about 2.0% lower if measured immediately after startup.)
I _o = 450 mA	91.0%	93.0%	-	
I _o = 700 mA	90.0%	92.0%	-	
EBS-080S105DTE				
I _o = 700 mA	90.5%	92.5%	-	
I _o =1050 mA	89.5%	91.5%	-	
Standby power	-	-	0.5 W	Measured at 230Vac/50Hz; Dimming off
MTBF	-	229,000 Hours	-	Measured at 220Vac input, 80%Load and 25°C ambient temperature (MIL-HDBK-217F)
Lifetime	-	120,000 Hours	-	Measured at 220Vac input, 80%Load and 75°C case temperature; See lifetime vs. T _c curve for the details
Operating Case Temperature for Safety T _{c_s}	-40°C	-	+90°C	
Operating Case Temperature for Warranty T _{c_w}	-40°C	-	+75°C	Case temperature for 7 years warranty. Please see Inventronics Warranty Statement for complete details. No condensation.
Storage Temperature	-40°C	-	+85°C	Humidity: 5%RH to 85%RH; No condensation.
Dimensions				
Inches (L × W × H)	4.93 × 3.35 × 1.42			
Millimeters (L × W × H)	125 × 85 × 36			
Net Weight	-	350 g	-	

Dimming Specifications

Parameter	Min.	Typ.	Max.	Notes	
Absolute Maximum Voltage on the Vdim (+) Pin	-20 V	-	20 V		
Source Current on Vdim (+)Pin	200 uA	300 uA	450 uA	Vdim(+) = 0 V	
Dimming Output Range	EBS-080S070DTE	10%loset	-	loset	450 mA ≤ loset ≤ 700 mA
	EBS-080S105DTE				700 mA ≤ loset ≤ 1050 mA
Dimming Output Range	EBS-080S070DTE	45 mA	-	loset	45 mA ≤ loset < 450 mA
	EBS-080S105DTE	70 mA			70 mA ≤ loset < 700 mA
Recommended Dimming Input Range	0 V	-	10 V		
Dim off Voltage	0.35 V	0.5 V	0.65 V	Default 0-10V dimming mode.	
Dim on Voltage	0.55 V	0.7 V	0.85 V		
Hysteresis	-	0.2 V	-		
PWM_in High Level	3 V	-	10 V		
PWM_in Low Level	-0.3 V	-	0.6 V	Dimming mode set to PWM in Inventronics Programming Software.	
PWM_in Frequency Range	200 Hz	-	3 KHz		
PWM_in Duty Cycle	1%	-	99%		
PWM Dimming off (Positive Logic)	2%	5%	8%		
PWM Dimming on (Positive Logic)	4%	7%	10%		
PWM Dimming off (Negative Logic)	92%	95%	98%		
PWM Dimming on (Negative Logic)	90%	93%	96%		
Hysteresis	-	2%	-		

Safety & EMC Compliance

Safety Category	Standard
ENEC & CE	EN 61347-1 ⁽¹⁾ , EN 61347-2-13
CB	IEC 61347-1 ⁽¹⁾ , IEC 61347-2-13
KS	KS C 7655
Performance	Standard
ENEC	EN IEC 62384
EMI Standards	Notes
EN IEC 55015 ⁽²⁾	Conducted emission Test &Radiated emission Test
EN IEC 61000-3-2	Harmonic current emissions
EN 61000-3-3	Voltage fluctuations & flicker

Safety & EMC Compliance (Continued)

EMS Standards	Notes
EN 61000-4-2	Electrostatic Discharge (ESD): 8 kV air discharge, 4 kV contact discharge
EN 61000-4-3	Radio-Frequency Electromagnetic Field Susceptibility Test-RS
EN 61000-4-4	Electrical Fast Transient / Burst-EFT
EN 61000-4-5	Surge Immunity Test: AC Power Line: Differential Mode 6 kV, Common Mode 8 kV
EN 61000-4-6	Conducted Radio Frequency Disturbances Test-CS
EN 61000-4-8	Power Frequency Magnetic Field Test
EN 61000-4-11	Voltage Dips
EN 61547	Surge Immunity Test: AC Power Line: Differential Mode 6 kV, Common Mode 10 kV
	Electromagnetic Immunity Requirements Applies To Lighting Equipment

Notes: (1) This product meets the requirements for EN/IEC 61347-1 [Annex O (Double insulation)].
 (2) This LED driver meets the EMI specifications above, but EMI performance of a luminaire that contains it depends also on the other devices connected to the driver and on the fixture itself.

Lifetime vs. Case Temperature

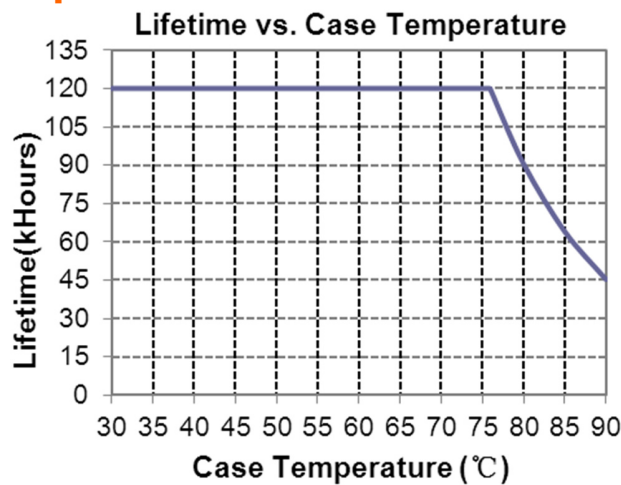

Inrush Current Waveform

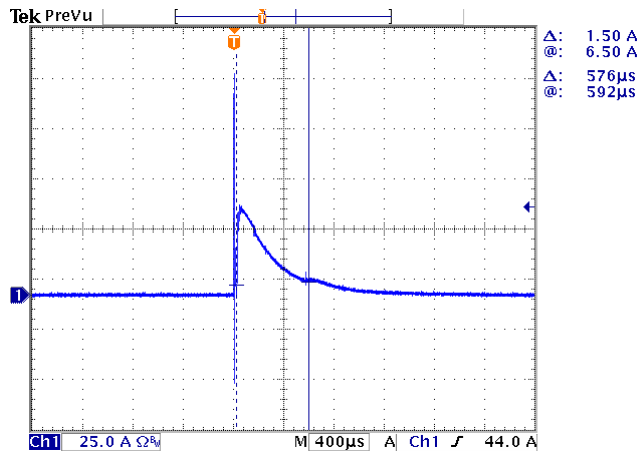

Efficiency vs. Load

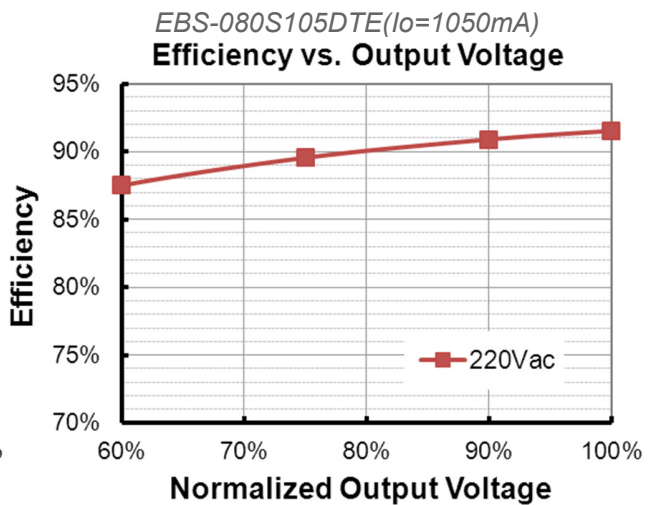
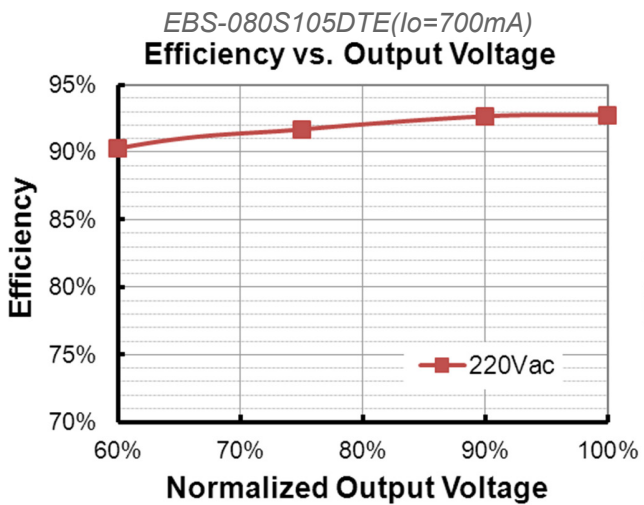
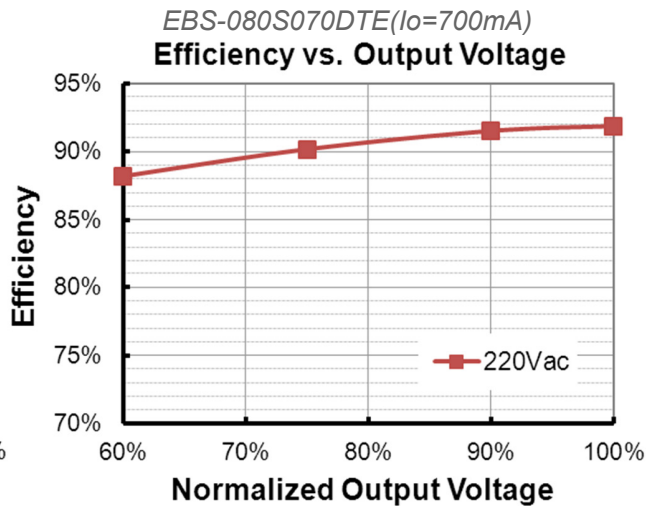
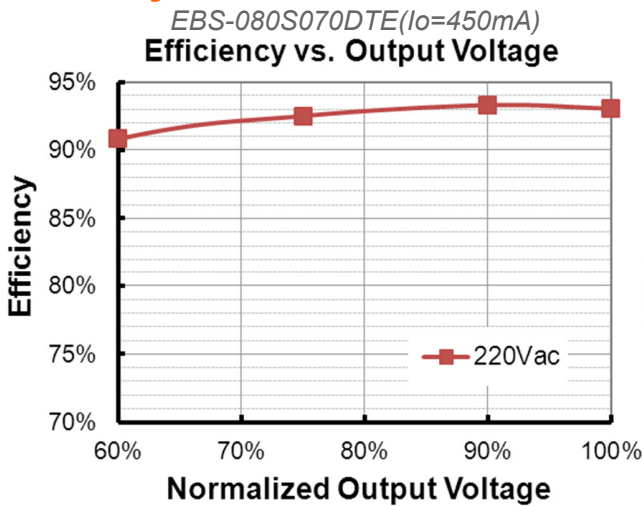

Power Factor

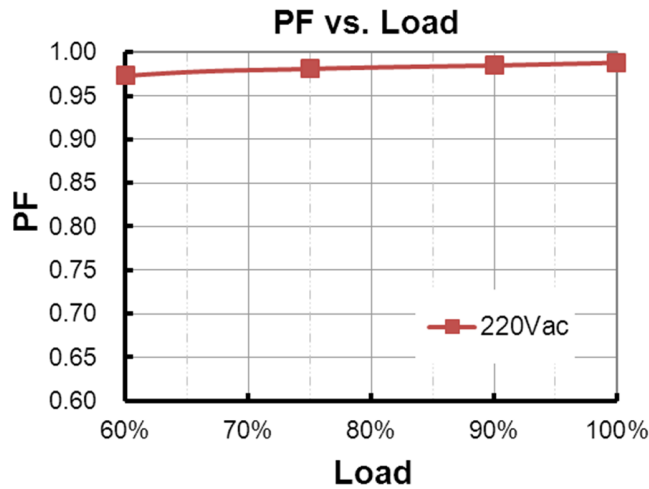

Total Harmonic Distortion

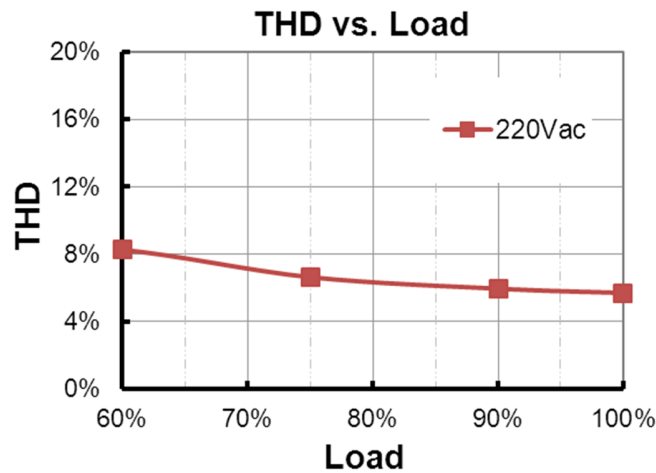

Protection Functions

Parameter		Min.	Typ.	Max.	Notes
External Thermal Protection NTC	R1	-	7.81 kOhm	-	When R_NTC falls below R1, External Thermal Protection is triggered, reducing output current until R2 is reached.
	R2	-	4.16 kOhm	-	When R_NTC is less than R2, output current is reduced to the programmed "Protection Current Floor."
	Protection Current Floor	10%I _{oSet}	60%I _{oSet}	100%I _{oSet}	10%I _{oSet} > I _{oMin} (default setting is 60%)
I _{oMin}		60%I _{oSet}	100%I _{oSet}	10%I _{oSet} ≤ I _{oMin} (default setting is 60%)	
Over Temperature Protection		Decreases output current, returning to normal after over temperature is removed.			
Short Circuit Protection		Auto Recovery. No damage will occur when any output is short circuited. The output shall return to normal when the fault condition is removed.			
Over Voltage Protection		Limits output voltage at no load and in case the normal voltage limit fails.			

Dimming

● 0-10V Dimming

The recommended implementation of the dimming control is provided below.

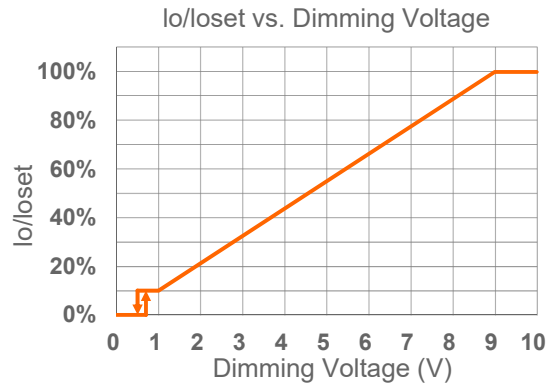
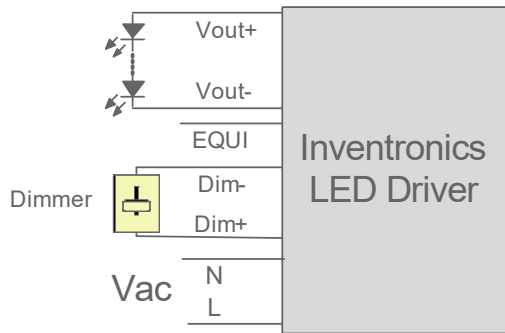

Implementation 1: DC Input

Note: The dimmer can also be replaced by an active 0-10V voltage source signal or passive components like zener.

● PWM Dimming

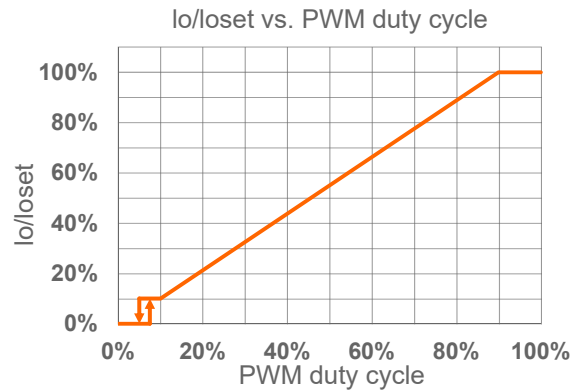
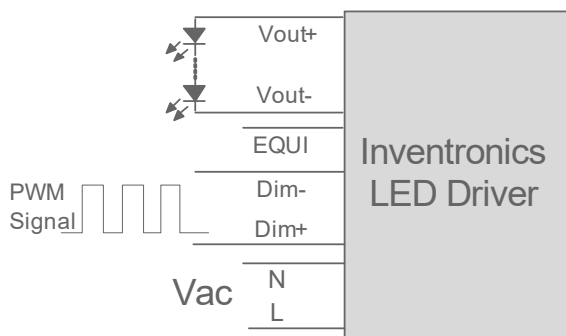

Implementation 2: Positive logic

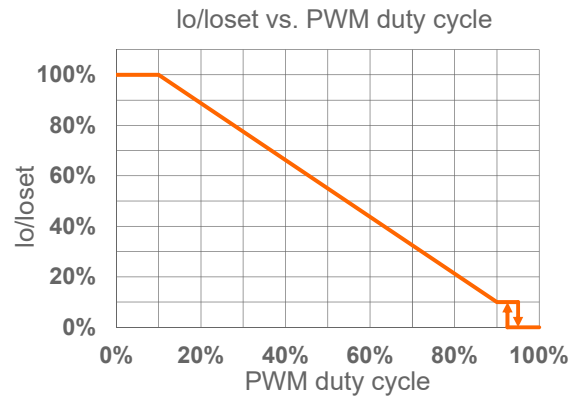
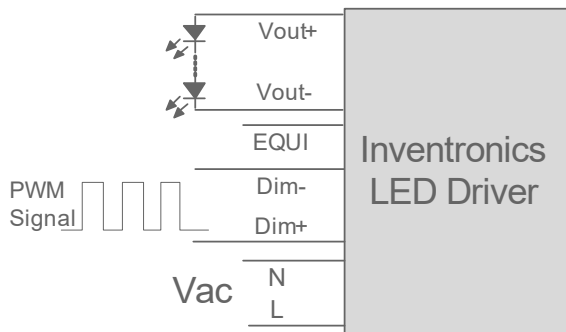

Implementation 3: Negative logic

● Timing Dimming

Time dimming control includes 3 kinds of modes, they are Self Adapting-Midnight, Self Adapting-Percentage and Traditional Timer.

- **Self Adapting-Midnight:** Automatically adjusts the dimming curve based on the on-time of past two days (if difference <15 minutes), assuming that the center point of the dimming curve is midnight local time.
- **Self Adapting-Percentage:** Automatically adjusts the on-time of each step by a constant percentage = (actual on-time for the past 2 days if difference <15 min) / (programmed on-time from the dimming curve).
- **Traditional Timer:** Follows the programmed timing curve after power on with no changes.

● Output Lumen Compensation

Output Lumen Compensation (OLC) may be used to maintain constant light output over the life of the LEDs by driving them at a reduced current when new, then gradually increasing the drive current over time to counteract LED lumen degradation.

Wire Connection Diagram

Parameter		Min.	Typ.	Max.	Notes
L, N	Wire Cross-section	0.4 mm ²	-	2.5 mm ²	Push-in at 0° angle, solid and stranded wire
		20 AWG	-	12 AWG	
	Strip Length	10 mm	-	11 mm	
EQUI	Wire Cross-section	0.4 mm ²	-	1.5 mm ²	Push-in at 45° angle, solid and stranded wire
		20 AWG	-	16 AWG	
	Strip Length	8.5 mm	-	9.5 mm	
Vout+, Vout-, Return, Tmon, +12V, Dim-, Dim+	Wire Cross-section	0.2 mm ²	-	1.5 mm ²	Push-in at 45° angle, solid and stranded wire
		22 AWG	-	16 AWG	
	Strip Length	8.5 mm	-	9.5 mm	

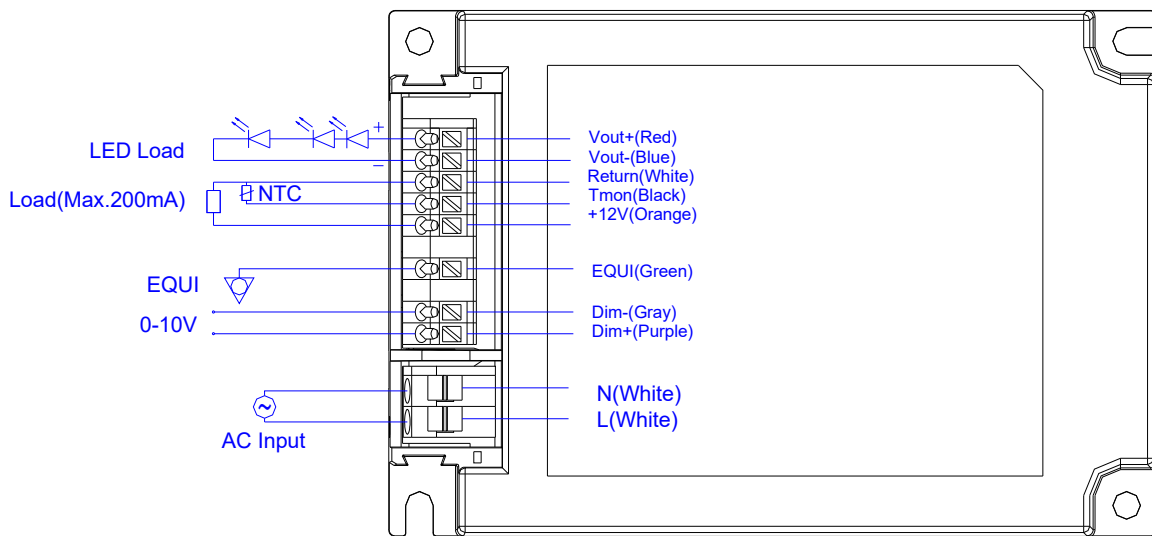

Programming Connection Diagram

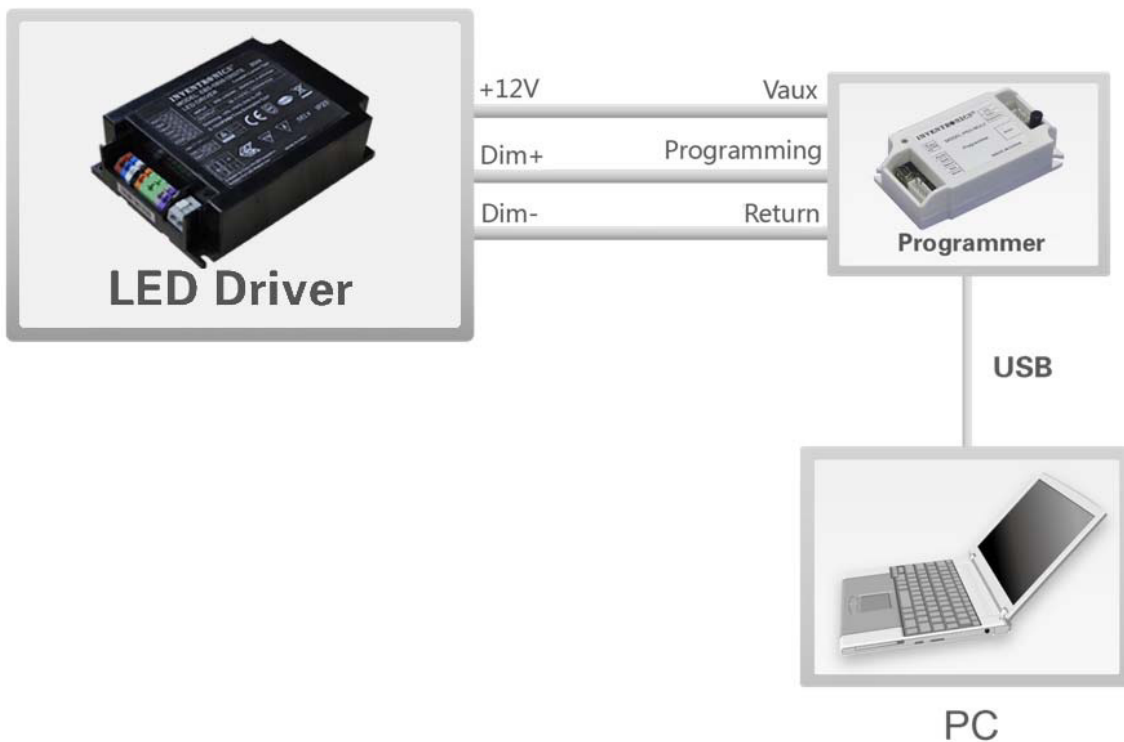

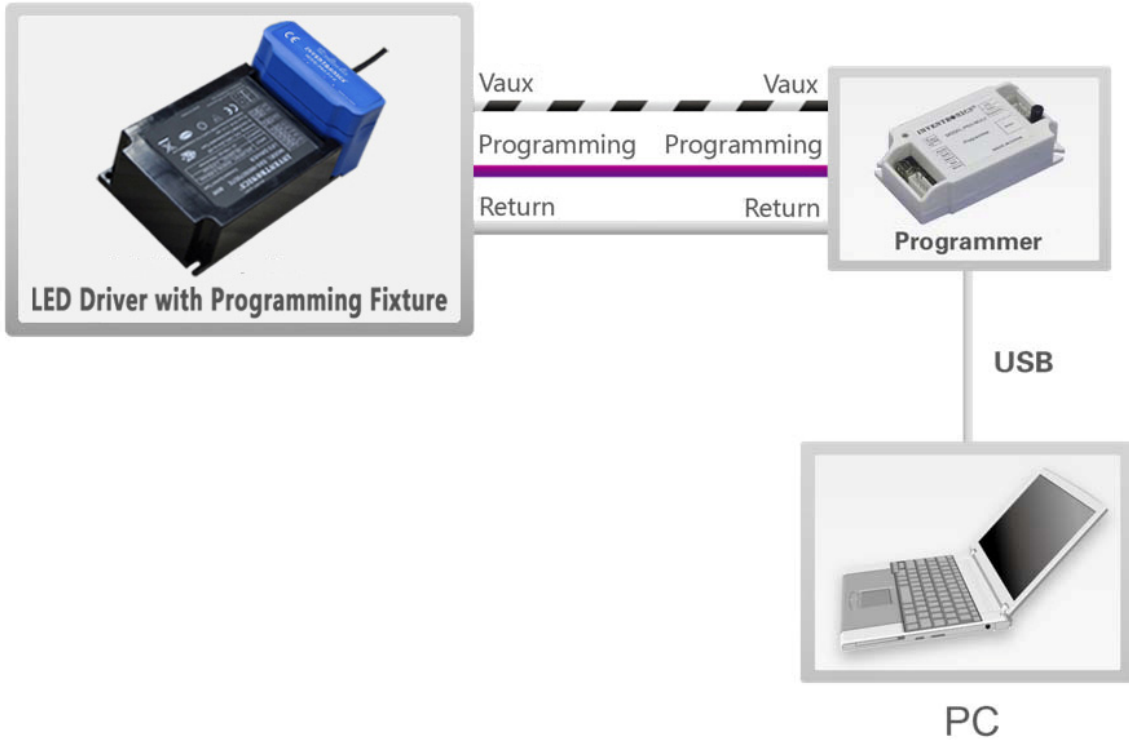

Note: The driver does not need to be powered on during the programming process.

- Please refer to [PRG-MUL2](#) (Programmer) and [PRG-FIX-E](#) (Programming Fixture) datasheet for details.

Mechanical Outline

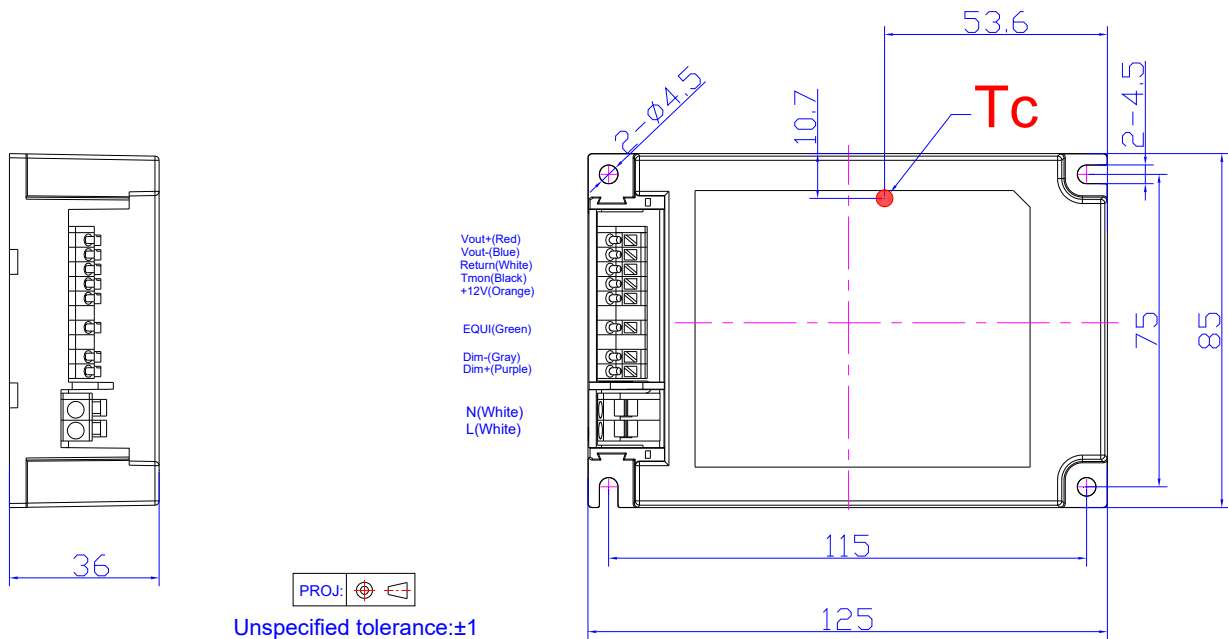

Optional Cable Clamp
END-CAP01

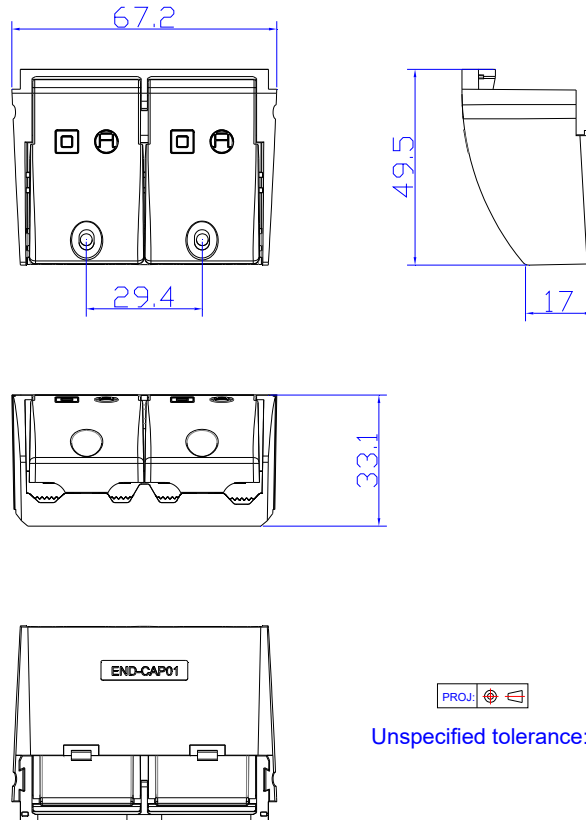

Note: The cable clamp is to be installed with EBS-080SxxxDTE drivers for independent application. Please refer to [END-CAP01](#) datasheet for details.

RoHS Compliance

Our products comply with reference to RoHS Directive (EU) 2015/863 amending 2011/65/EU, calling for the elimination of lead and other hazardous substances from electronic products.

Revision History

Change Date	Rev.	Description of Change		
		Item	From	To
2016-09-09	A	Datasheets Release	/	/
2017-10-24	B	Features	7 Years Warranty	Added
		Features	Always-on Auxiliary Power	Added
		Input Specifications	PF/THD	Updated
		Output Specifications	Temperature Coefficient of I _o set	Updated
		Output Specifications	12V Auxiliary Output Transient Peak Current	Added
		General Specifications	Operating Case Temperature for Warranty T _{c_w}	Updated
2018-01-26	C	Description	/	Updated
		Operating Case Temperature for Warranty T _{c_w}	Notes	Updated
		Wire Connection Diagram	/	Updated
2024-08-22	D	Format	/	Updated
		Product Photograph	/	Updated
		TUV/CCC logo	/	Deleted
		Models	Notes(3)	Updated
		Safety & EMC Compliance	/	Updated
		RoHS Compliance	/	Updated